



# Internet Space Builder 3.0

## **User's Guide**

# Contents

<b>WELCOME TO INTERNET SPACE BUILDER .....</b>	<b>1</b>
What is ISB.....	1
ISB Features .....	1
ISB Quick Start Guide .....	1
Getting Help .....	2
Getting assistance.....	2
Hardware and system requirements.....	2
Installation .....	2
Uninstalling ISB.....	3
Technical support.....	3
ParallelGraphics Web Site.....	3
Frequently asked questions.....	3
<b>GETTING STARTED .....</b>	<b>4</b>
Screen Layout .....	4
Customizing layout.....	5
Working with menus.....	5
ISB Scene Building Concept.....	6
Scene Building .....	6
Example of stone statue.....	6
Structured scene .....	7
Keeping the virtual world clear .....	8
Two modes of a scene construction.....	8
Editing objects in the Object Editing mode.....	8
Galleries of Already Built Items and Examples .....	9
Galleries of ready items in ISB .....	9
How does <i>ISB</i> store the files of galleries.....	9
Phases of building the virtual space.....	10
<b>BASIC OPERATIONS .....</b>	<b>10</b>
Creating, Opening and Saving 3D Scenes .....	10
Create a new scene .....	10
Open an existing scene.....	10
Save a scene.....	11
Controlling Camera.....	11
Control cameras.....	11
Navigate cameras in the Plan window.....	12
Navigate active camera in the Perspective View window.....	12
Navigate active camera in the Ruler window.....	13
Align cameras.....	14
Duplicate cameras.....	14
Set active camera.....	14
Rename cameras.....	14
Delete cameras .....	15
Constructing Scene .....	15
Construct scene .....	15
Include ready shapes into a scene.....	15
Include shapes created on the fly.....	16
Set shape position, size and orientation.....	17
Apply shapes to scene .....	18
Controlling Shape Heights.....	18
Control shape heights .....	18
Set shape's default height.....	19
Change shape heights .....	20
Scroll the Ruler.....	20
Creating New Shapes.....	20
Create custom shapes .....	20

Manipulating Plan .....	21
Split the Plan window .....	21
Turn the Grid on/off .....	21
Rotate a plan .....	21
Scroll a plan (pan the view port) .....	22
Zoom of plan .....	22
Fit a window to a scene .....	22
Print a plan .....	23
Using Shapes in the Perspective View Window .....	23
Placing shapes in the Perspective View window .....	23
Set shape position, size and orientation in the Perspective View window .....	24
View window .....	24
ISB Limits .....	25
Scene Background and Landscape .....	25
Scene background schemes: overview .....	25
Setting the scene background and landscape scheme .....	26
Editing Background colors .....	29
Using Colors and Textures .....	30
Setting the Face Material properties: overview .....	30
Using face materials .....	30
Applying default material to faces .....	31
Material Bar .....	31
Apply textures .....	32
Setting face colors .....	33
Spreading materials .....	33
Using Pictures and Movies .....	34
Set pictures/movies onto a face .....	34
Specify movies play order .....	34
Copy pictures/movies .....	34
Change pictures/movies location .....	35
Resize pictures/movies .....	35
Delete pictures/movies .....	35
<b>ADVANCED FEATURES.....</b>	<b>36</b>
Using Objects .....	36
Use objects .....	36
The Scene Tree .....	36
Place Objects into the scene .....	36
Working with the Geometry Clipboard Content .....	37
Import objects .....	38
Manipulating Objects .....	38
Select objects .....	38
Create objects .....	39
Saving current object .....	39
Deleting objects .....	40
Renaming objects .....	40
Get object info .....	40
Move and copy objects into another place in scene .....	40
Move and copy objects into another hierarchy level .....	41
Fitting windows to objects .....	41
Editing Objects .....	41
Edit objects .....	41
Changing size, position and orientation using Object Manipulator .....	42
Changing object's height using the Ruler .....	43
Add and extract shapes .....	43
Cut, copy, and paste objects and their parts .....	43
Manipulating Objects in the Perspective View Window .....	44
Manipulating objects in the Perspective View window .....	44
Object manipulator controls in the Perspective View window .....	45
Rotating the object directly in the Perspective View window .....	45
Scaling the object directly in the Perspective View window .....	46
Moving the object directly in the Perspective View window .....	47
Using VRML Geometry Primitives .....	51
VRML primitives: overview .....	51

Box VRML primitive object .....	51
Cylinder VRML primitive object .....	52
Cone VRML primitive object .....	53
Sphere VRML primitive object .....	54
<b>Using Plain Text Objects .....</b>	<b>54</b>
Using Plain Text objects .....	54
<b>Using 3D Fonts .....</b>	<b>55</b>
<b>Multimedia Capabilities .....</b>	<b>56</b>
Attach sound .....	56
Play sound .....	57
Detach sound .....	57
Link URLs .....	57
Removing URLs .....	58
<b>Publishing Scene .....</b>	<b>58</b>
Preparing the scene for publishing .....	58
Upload scene to the World Wide Web .....	58
<b>Texture Mapping .....</b>	<b>58</b>
Switching to the Texture Mapper window .....	58
Placing textures into the Texture Mapper window .....	59
Moving textures .....	59
Mapping the texture relative to a pivot point .....	59
Mapping textures relative to a line .....	60
Restoring the initial texture .....	61
Changing texture transparency .....	61
Removing textures .....	61
Animating textures .....	61
Copy modified textures to faces .....	62
<b>Texture Painting .....</b>	<b>62</b>
Switching to the Painter window .....	62
Creating a new picture or texture .....	63
Placing pre-existing textures or pictures into the Painter window .....	63
Draw a straight line or rectangle .....	63
Draw a free-form line .....	63
Fill an area with a color .....	63
Using transparent colors .....	64
Manipulating selected areas .....	64
Pick up a point color .....	65
Zoom In a picture or texture .....	65
On-line picture or texture editing .....	65
Resizing a picture or texture .....	65
Saving a picture or texture .....	65
<b>Controlling Gallery Resources .....</b>	<b>66</b>
Moving, adding and deleting gallery resources .....	66
<b>Working with the Scene Resources and Resource References .....</b>	<b>66</b>
Working with the resources, used in the Scene .....	67
Viewing where the selected resource is used in the scene .....	68
Renaming resources .....	68
Changing resource reference in the scene file .....	69
<b>Controlling the navigation type .....</b>	<b>70</b>
<b>Setting ISB options .....</b>	<b>71</b>
General .....	71
The HTML options dialog box .....	71
Plan .....	71
Camera .....	72
Galleries .....	72
Texture Mapper .....	72
<b>Keyboard Navigation dialog box .....</b>	<b>73</b>
<b>Customizing Toolbars .....</b>	<b>74</b>
Display or hide toolbar .....	74
Disable or enable custom toolbar .....	74
Move a toolbar .....	74
Resize a toolbar .....	74
Restore a built-in toolbar .....	75
Create a custom toolbar .....	75

Delete a custom toolbar .....	75
Rename a custom toolbar .....	75
Add or delete a toolbar button .....	76
Change the spacing between toolbar button .....	76
Move or copy a toolbar button .....	76
<b>TROUBLESHOOTING .....</b>	<b>77</b>
<b>REFERENCE .....</b>	<b>78</b>
Main Menu.....	78
Toolbars .....	81
<b>INDEX .....</b>	<b>87</b>

# Welcome to Internet Space Builder

## What is ISB

ParallelGraphics Internet Space Builder (*ISB*) lets you easily create 3D worlds and publish them on the World Wide Web. Anyone can visit and experience your 3D Web site using standard VRML2.0 browsers. *ISB* adds a new dimension of reality to your Web sites with a complete library of editable 3D shapes. Combined with interactive texture mapping *ISB* brings your 3D space to life.

## ISB Features

*ISB* includes features that help you work conveniently and quickly. These features include:

- Creating and editing true 3D scenes and objects using 3D Boolean operations (adding and subtracting) over a broader range of 3D primitives such as spheres, pyramids, cones and cylinders.
- VRML 2.0 compliance: you can import and export scenes and objects in VRML 2.0 format as well as view created scenes in all major VRML browsers, such as Intervista World View, Cosmo Player, and others.
- Utilizing rich galleries with standard shapes, textures, pictures, objects and movies.
- Importing 3DS objects (3D Studio), DXF files (AutoCAD), MUS (VHSB), and D96 files.
- Exporting in AutoCAD DXF format.
- Creating additional viewpoints (cameras) with possibility to select a camera from the list.
- Visual support for a user-defined object hierarchy on the Scene Tree.
- Advanced interactive texture mapping and editing, setting material transparency and color and the ability to draw directly on textures with immediate display of all changes in the 3D space.
- Creating and formatting 3D fonts.
- One-button posting of VRML scenes to the Web.
- Customizable user interface with multiple layouts.
- Support for the VRML geometry nodes Box, Cone, Cylinder, Sphere, Text
- Using 8-bit (256 color mode), 16-bit (high color mode), 24-bit (true color mode) and 32-bit (true color mode with advanced lighting) rendering modes. Support for Intel's MMX® instruction set.
- Capability of creating a shape using a smooth curve (Spline Mode).
- Optimization of VRML output.
- Capability of choosing the scene landscape from a set of pre-defined landscapes.
- Customizable keyboard navigation commands for the camera.
- Change, rename, and format conversion operations for the resource files, referenced in the scene file.
- Editing operations directly in the Perspective View window.
- Importing and exporting worlds in compressed VRML 2.0 format (gzip).

## ISB Quick Start Guide

An HTML document that provides tutorials on the features of *ISB* and reference information. It is shown when you start *ISB* for the first time and also available from the start menu in the default Internet browser or at the Tutorials tab of the Switch bar.

## Getting Help

### Getting assistance

You can get help without interrupting your work. For an explanation of any item such as a menu command, a toolbar button, a dialog box, or a screen item:

-  Click the Help button on the Standard toolbar, and then click the item. Or
- Position the pointer over the menu item and press F1.

For a brief description of a menu command:

- Position the pointer over the command. The description will appear on the Status bar.

For a description of a toolbar button:

- Position the pointer over the button. The name will appear below the button.

### Hardware and system requirements

- Operating system: Microsoft® Windows® 95/98 or Windows NT® 4.0.
- Computer: 486 or better, Pentium® is recommended.
- Random Access Memory (RAM): minimum of 8 MB.
- Free disk space: 12 MB of hard disk space for program files, recommended free space for swap file growing - 40 MB.
- Display: SVGA/256 colors. The 800x600, high color mode is recommended.
- Interface: Mouse and keyboard, optional pen.
- CD-ROM drive: optional.
- Sound card: optional.

### Installation

*ISB* is available in two types of installation packaging: either as a downloadable package (electronic online distribution) or on CD ROM. The Setup program provided with each package creates all the necessary folders on your hard disk and installs all necessary software components along with content libraries. To install *ISB*:

- 1 Start Windows.
- 2 Run setup.exe program from the *ISB* installation package. An *ISB* Setup splash screen appears.
- 3 Follow setup.exe instructions.

The Setup program automatically creates *ISB* program group.

- Double-click the ReadMe icon for up-to-the-moment product news.
- To start the program click the Start button, point to Programs, point to Internet Space Builder, and then click Internet Space Builder.

**Note:**

You may read the *ISB* Quick Start Guide document by clicking Quick Start Guide.

## Uninstalling ISB

To remove the *ISB* program:

- 1 Click the Start button and then point to Settings.
- 2 Click Control Panel, and then Double-click the Add/Remove Programs icon .
- 3 In the dialog box select Internet Space Builder 3.0 and click the Add/Remove button.
- 4 Click Yes if you want to remove the *ISB* installation completely. Click No if you decided to keep *ISB*.

### Notes:

- The UninstallShield program deletes all the standard *ISB* components, standard gallery files and registry entries. You must manually remove any shortcuts to *ISB* you have created elsewhere.
- The UninstallShield program does not delete the elements which you created by yourself in any gallery. The corresponding gallery folders are also not deleted. You may use them later with the newly installed *ISB*.

## Technical support

We are interested in receiving your comments and suggestions about *ISB*. For product support, send e-mail to [support@parallelgraphics.com](mailto:support@parallelgraphics.com). Before posting your message, please follow these simple instructions:

- 1 Check the Quick Start Guide and online Help.
- 2 In your message include any information that could help answer your question or solve the problem.
- 3 Document the system configuration: OS version, CPU type, memory, sound card, graphics card, monitor, etc.
- 4 When error messages occurs please document the complete message including sub dialog details and provide step-by-step instructions for reproducing the problem.

## ParallelGraphics Web Site

Visit <http://www.parallelgraphics.com> on the World Wide Web for the latest information on our company, future product releases, and as a central location for visiting other *ISB* 3D spaces.

## Frequently asked questions

- I cannot save in .MUS or VRML 1.0 formats.  
*ISB* allows you to save the created scene both in the VRML 2.0 and .dxf (AutoCAD) format. The MUS format (the Virtual Home Space Builder format) is supported for reading only. That is to say, if you have a scene in VHSB, you can view and edit it in *ISB*, but cannot save it as a .MUS file again.
- Can *ISB* read a VRML 2.0 file prepared in any other editor?  
Yes, *ISB* can read VRML 2.0 files prepared in other editors. If the file contains any sentence not implemented in *ISB* that sentence is ignored with warning "VRML file contained some information, which *ISB* cannot save in the original form. To prevent loss of data save to different name.
- May I create my own objects?  
Yes, you may create your own objects using *ISB* and save them in the Object Gallery, or import the objects from the 3D Studio file format.
- Can I walk through the walls in *ISB*?  
To walk through the walls in the Perspective View window release the Collider button on the Camera toolbar. You can freely navigate a camera through the walls in the Plan window.
- Can I place links to HTML pages or other VRML worlds?



Yes, the HTML links can be attached to pictures, movies and other scene objects. To link a URL, right-click the object you wish to link in the Scene Tree window, a pop-up menu appears which contains the Link URL option.

- I couldn't find an option to get the split modeling screen for top and side viewpoints. Is there an option somewhere that I don't know of?  
To simulate a side-view, you can use the Plan wheel located on the bottom of the Plan window. For example, to get the plan left view, rotate the Plan wheel to the right until its next black mark fit the red triangle. You can rotate the Plan wheel with the mouse.
- Can I make the shape rotation smooth?  
Yes, to do this, rotate the shape while holding down the Ctrl key.
- Can I increase or decrease a shape in two directions simultaneously?  
Yes, to do this, increase or decrease the shape while holding down the Shift key.
- Can I increase or decrease a shape in all directions keeping its proportions?  
Yes, to do this, press Gray + key on the numeric keypad to increase the shape or press Gray - key to reduce the shape.
- Can I texture a whole object?  
Yes, to texture a whole object, you must texture one of its faces, click the Spread button on the Brush toolbar, then Double-click the face in the Perspective View window. The whole object will then be textured.

## Getting Started

### Screen Layout

Screen elements can be grouped in a variety of standard and custom layouts. When you launch *ISB* for the first time, the following Basic screen layout appears:

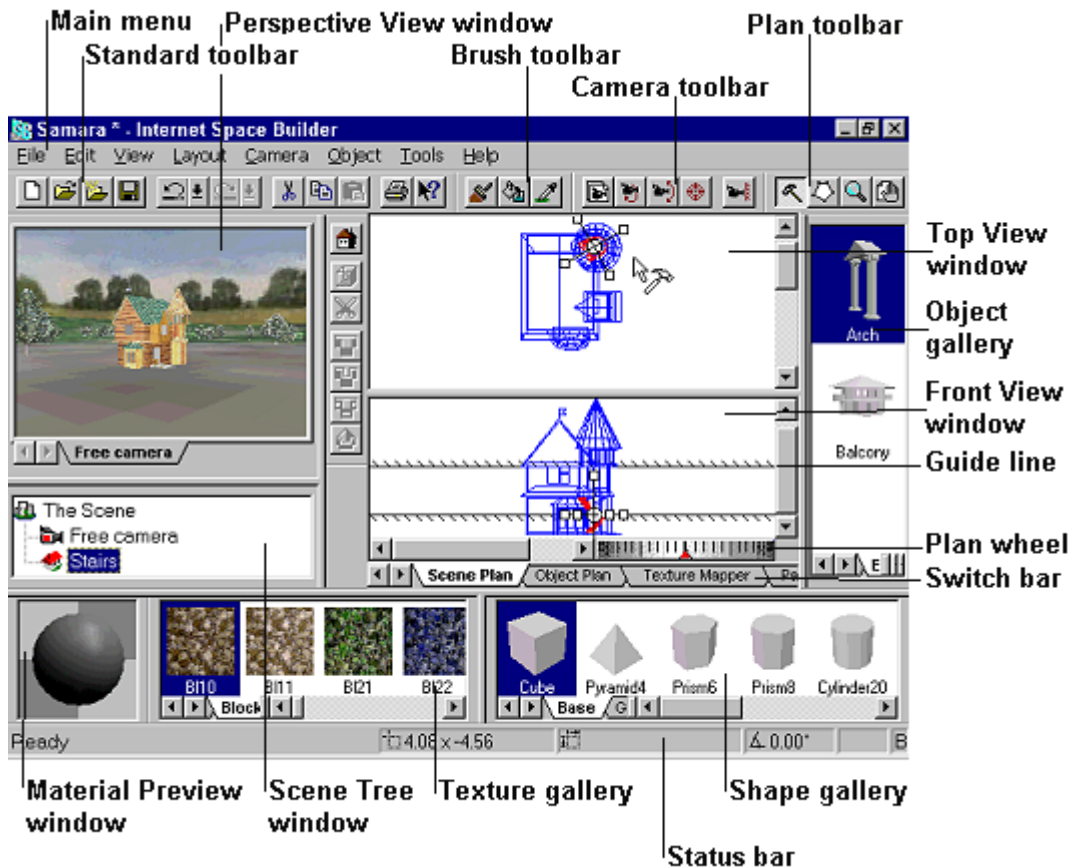

By default, this layout includes Perspective View window, Plan window, Scene Tree window, Material Preview window, Texture gallery, Shape gallery, Object gallery, Standard toolbar, Edit toolbar, and Plan toolbar.

**See also:**

- "Screen View Elements" section in *ISB's Quick Start Guide* document.

**TIP:**

- You can read the explanation of all ISB menu and toolbar buttons commands for this layout in the "Reference" section in *ISB's Quick Start Guide* document.

## Customizing layout

The following options are supported in customization:

- You can choose different layouts using the Layout menu.
- It is possible to enable/disable various screen elements using the View menu.
- The screen elements can be resized and positioned.
- You can also save custom layouts using the List item feature on the Layout menu.

To choose a layout:

- Choose one of the available layouts from the Layout menu. Basic layout is available by default. You may add new layouts to this set.

To add a new, user defined layout to the set of available layouts in the Layout menu:

1. Customize the screen layout to your desired standards.
2. Choose List from the Layout menu.
3. In the dialog box choose Add command and specify the name of new layout.

To resize and change the position of screen elements:

- Drag the window border to set the desired window size.
- Drag the window margin to change its position on the *ISB* screen.

To customize the toolbars refer to the "Customizing Toolbars" topic of this document.

**Notes:**

- You may delete the user-defined layout by choosing List/Remove command from the Layout menu. The default layouts can not be removed.
- *ISB* saves the layout you used before closing. Thus, restarting the program returns you to the same layout type, set of visible windows, their sizes and positions, toolbars, which were in place when you closed the *ISB* session.
- The scene image in the Perspective view window is resized together with the window, not clipped. This is similar to viewing a real video camera image on TV screens of different sizes: you always see the same image, but re-sized to accommodate the screen size.

## Working with menus

Working with *ISB*, you can use the main menu and toolbar commands to create and edit virtual 3D space. Refer to the "Reference" chapter for the description of all menu commands. You may also use on-line context help for brief description of commands.

Most of the operations in *ISB* can be performed in several ways: using the Main Menu, clicking the Toolbar buttons, drag and drop operations or the context-dependent pop-up menu commands.

To activate the context-sensitive pop-up menu:

- Right-click the item anywhere on the *ISB* screen. The context sensitive menu appears. The operation achieved by a Double-clicking the item is displayed in a bold font. Some operations are

not available for the certain objects and are grayed out. You can get help on each item by selecting it with the mouse pointer and pressing F1 button.

## ISB Scene Building Concept

### Scene Building

The fundamental notion describing the 3D space you are creating is the scene. It is actually the world you create, edit and see in the Perspective View and Plan windows. All items of your virtual space are inside the scene. As a living 3D space, the scene always exists, and you can not delete or resize it.

Every scene may include a “frozen and the “mobile parts:

- Adding shapes directly to the scene creates the frozen part. Later you can carve them using other shapes from the scene. But when you add a shape directly everything you do in the scene becomes unmovable. You can not move or resize these items in the scene itself. See “Example of stone statue” for illustrating the concept.
- The mobile part of scene consists of objects. Objects can be created by merging and carving with shapes, imported from *ISB*'s Object gallery, or directly from geometry files like 3DS files. Objects can be edited and may include sub-objects, thus forming the Scene Tree (object hierarchy). Creating objects and establishing the relationship between them, you make the structured scene, containing information about the world you have created (see “Structured scene”).
- The frozen and mobile parts of the scene are both important for the creation of a 3D world. Read our comments on how to use them effectively and keep your virtual world clear and easy for editing (see “Keeping your virtual world clear”).

We recommend you to read these three topics for a better understanding of the *ISB* world creation concept.

### Example of stone statue

The following example from the real world may help you to understand the concept of a frozen part in the scene.

- Imagine you decide to make a big stone statue somewhere (a 3D scene in *ISB*). Although you may choose any piece of stone, typically you go to some shop (Shape gallery in *ISB*) and decide what should be the shape of the piece you would like to buy. After choosing a shape from a set in the shop you have to decide what shape dimensions are suitable for your statue. For this, you draw a shape on the plan of your working space (include ready shape into scene operation in *ISB*). You may re-draw it several times, changing shape position, orientation, size and proportions (doing the same in *ISB*), until you make a decision regarding which piece to order from the shop. After the piece of stone (shape) has been moved to the place you specified (Add to scene operation), you can not move it, because it is too heavy. For you, it is frozen and all you can do is to cut a piece from it or add another. You can not re-size the stone or change its proportions in our real world through commands or magic. The same is true for the scene in *ISB*, with the only one difference: the stone may float in the air, but is still too “heavy to move it.
- Adding a new piece of stone is similar to the above operation. You choose a shape, make a decision about the position, orientation, etc., and order where to place it (Add to scene). If the new shape intersects with the existing one, in the real world you would glue the additions to the already existing shape's faces. The glue you use is perfect, so the result is a new, solid piece of stone. After adding the piece, you cannot distinguish between the “old stone and the “new stone. If you place a separate piece of stone somewhere near the previous one, it is always too heavy to move it by yourself. In the *ISB* scene you have the same situation.
- To cut the stone you have to use different tools. First, decide what shape you want to extract from

the stone. Go to the workshop (Shape gallery in *ISB*) and select the tool, suitable to cut the cubic, cylindrical, spherical or other shape you would like to carve in the stone. Then you draw it several times (place draft shapes into the scene in *ISB*) on the plan of your statue to define the shape's position, orientation and proportions. Finally you use the tool (Extract shape from the scene in *ISB*) and cut the piece from the stone. In contrast to the real world, in the *ISB* scene you may cut the "stone into several parts, floating in the air, without being afraid that they fall down.

The concept of frozen stones works in the *ISB* scene. In other words, the *ISB* program treats the scene as a set of faces, which do not differ from each other and do not have any history of creation. The model of frozen stones allows you to simplify the structure of the scene file and reduce its size. The more complex concept of a Structured scene is described in the next section.

## Structured scene

Construction of complex scenes requires that you structure the scene. This allows you to have different moveable items and to introduce relationships between them. In the "example of stone statue" the information about scene structure was lost immediately after applying the shape to it.

Now, imagine that you are creating the statue in the bed of a truck. While you are still unable to change the statue, you can move the statue as a whole in the scene space. In *ISB* terms, you have defined the statue as an object, which is now moveable over the scene. The "truck is not visible in the 3D space, but you can move and turn the object in any direction and even re-size it at any time. While some of this capability has no direct analogy in the real world, the concept allows you to edit complex scenes easily. The bed of the virtual "truck (object) has similar properties as the scene itself. The building and editing rules for the object are the same as for the scene. You may add and extract shapes to/from an object. As in the scene, you can not resize or move items inside the object separately from each other. The difference is that now you can move and resize the entire object and save it in the Objects gallery in order to use it later.

The items inside the object are the same "frozen stones as in the scene. However, you may define a "secondary truck (sub-object), which can move items over the primary (parent) truck. The rules for creating and editing items in sub-object are the same as for its parent object. Further more, you may create third-, fourth-, etc. order "trucks each having the "frozen stones" structure inside and one or more moveable sub-objects.

The set of objects forms the moveable part of the scene, but this part also has a structure. This means that each object is a sub-object of some parent object or the whole scene and may have sub-objects inside. Such relationship is defined by the following rules:

- When any object is resized/moved all its sub-objects and their child sub-objects are re-sized/moved by the same factor/distance.
- When any object is saved/deleted, all its sub-objects and their child sub-objects are saved/deleted too.
- The above two operations, when applied to the sub-object, do not affect its higher level (parent) object.
- Editing of the frozen part of an object does not affect any other object.
- You may change the relationship between the objects freely.

The scheme of relationships between the objects is displayed in the Scene Tree window in the form of a tree. The root of a Scene Tree is a scene itself. It may have a number of nodes-objects, and each of them may have sub-objects.

The structured scene concept helps you in editing your 3D space. Imagine you are creating the Galaxy (scene) with the Sun (object) and the planets (sub-objects) around, among which is the planet Earth with your house (third level object of Scene Tree). Inside the house you may have a table. When you move the Sun, you expect that all planets and everything on them move too. You expect also, that the house where you live stay on ground in the same place while the Earth is moving around the Sun. And you are sure, that changing or destroying the table in your house does not destroy the Earth or entire Galaxy. The concept of structured Scene Tree in *ISB* helps you to keep the relationships between objects according to the common sense.

Advice on keeping your virtual world clear is located within the next topic.

## Keeping the virtual world clear

The model of structured world in *ISB* is very useful. You may define the structure and the relationship between the items in the virtual world in any way you like. However, it is important to keep your virtual world “clear: the dependencies you introduce must be easy to understand even after returning to the editing of your virtual world several weeks after its creation. Although it may be humorous enough to state that the wind is the result of ocean waves, you may forget this joke later and return in your mind to the common concept. The following notes may help you to keep the space in order:

- When using *ISB* you are creating virtual world, so you do not have to rely on normal rules of reality. You can make the Sun a sub-object of the table in your room. However, introducing “strange dependencies into the Scene Tree makes editing difficult. You may get unexpected transformations of items or suddenly delete the Sun along with your table. We recommend keeping the “native order of the objects in your virtual world.
- Although you can make the frozen part of the object complex enough by applying the shapes, we recommend to create the visually separated items as new objects (see “Create objects”). Doing so you may easily rearrange them in space and in the Scene Tree as well as save them in the Objects gallery separately.
- Contrary to what is mentioned above, you should try to make items, consisting of several merged shapes as a frozen part of single object. In this case the internal, not visible faces of item are destroyed while applying the shape, thus simplifying the object structure, reducing the file size and increasing the speed of any VRML 2.0 viewer.
- Be careful creating and importing new objects. Always track their position in the Scene Tree. This will help you to escape the “strange dependencies and make your virtual world easy to edit.

## Two modes of a scene construction

*ISB* has the two main modes for 3D virtual reality construction. These are: the Scene assembling mode and the Object editing mode.

The first - Scene assembling mode, is intended for assembling a scene from the different parts prepared before. These parts can be the frozen scene components, different shapes, objects from the Object gallery, pictures and movies. In this mode you usually construct the frozen scene parts (using shapes, textures and colors), and then place into the scene different mobile parts (objects, pictures and movies) adjusting their size, location, and color and texture attributes. In this mode the whole scene is displayed both in the Perspective View and Plan windows. The Scene assembling mode is the *ISB* default mode.

The second - Object editing mode, allows you to construct a new object or modify the existing one to use during scene assembly. In this mode only the editing object is displayed in the Perspective View and Plan windows. The whole scene is returned to display mode after the object editing is finished and the Scene assembly mode is restored. The edited object can be saved in the Object gallery, or placed into the clipboard or scene.

You can switch between two modes with the Switch bar. Clicking the Scene Plan tab switch *ISB* in the default Scene Assembling mode, while clicking the Object Plan tab enters the Object Editing mode.

### TIP:

You can learn more about building the scenes with the help of “Examples”, given in *ISB*'s Quick Start Guide document.

## Editing objects in the Object Editing mode

To enter the Object editing mode do one of the following:

- Choose Edit on the Object menu to edit the current scene object
- Choose New Empty Object on the Object menu to create a new object
- Double-click an object in the Object gallery to edit the selected object
-  Click New Object on the Edit toolbar

 Click Object Plan tab in the bottom of the Plan window to edit the selected object.

After switching to the Object Editing mode, images of all the objects are removed from the Plan and Perspective View windows except the currently selected object and its sub-objects. The plan scale for the object is adjusted automatically, and the Go To Object command of the Camera menu is executed.

To edit the object you can use the Object manipulator, the Ruler, and shapes.  
After the editing is finished:

 Click the Scene Plan tab to return to the Scene Assembling mode:

- If an object edited is not yet in the scene, the Save object dialog box is presented for choosing a saving mode. See the Create objects section to learn detailed methods for saving objects.
- If the object edited is already present in a scene, the scene will be restored in the Plan and Perspective windows. See the Saving object section to learn how to save a changed object to the object gallery.

**See also:**

“One level house” example in the ISB's Quick Start Guide document.

## Galleries of Already Built Items and Examples

### Galleries of ready items in ISB

The *ISB* compact disk contains not only the executable program, but also a rich collection of pre-built items, located in the Galleries of Scenes, Objects, Pictures, Textures and Movies.

All items in the Scene and Object galleries were built with *ISB*. You may load the ready scenes to see the capabilities of *ISB*. While viewing the scenes, you may also see their internal structure in the Scene Tree window. Note, that most of the scenes contain both the frozen and the mobile parts (objects). Explore the scene structure to learn more about how to build your own scenes.

The items in the scenes of the Scene gallery are painted with colors and textures. However, all scenes are also saved as non-colored objects in the Examples category of Object gallery. So, if you want to start building your 3D space with the ready-made “house you may place the corresponding object from the Object gallery into your new scene and apply the colors and textures to its faces in any way you like. Aside from the Examples category, the Objects gallery also contains two more ready categories: Furniture and Plants, which are the collection of 3D furniture items and plants.

### How does *ISB* store the files of galleries

If you purchase *ISB* 3.0 on CD ROM, the way, in which the *ISB* program stores and saves the contents of its galleries (resources), depends on the type of installation:

- For a Typical installation, the files of all galleries are copied and stored in the correspondingly named sub-directories of the main *ISB* directory on your hard disk. For the galleries, which are divided into several categories, all items are saved into the sub-directory of the gallery directory.
- Using the Compact installation, all files from the galleries, except the Shape gallery are stored on the compact disk.
- With the Custom installation you may choose the galleries, and therefore which files will be copied to the hard disk.

**Note:**

- All newly created or edited items (Scenes, Objects, Pictures, Textures and Movies) are saved in the sub-directories of the *ISB* directory, regardless of the type of installation of the *ISB* program. So every time when you edit an item, the corresponding file with modified item is copied to the gallery's sub-directory on your hard disk.

## Phases of building the virtual space

The *ISB* compact disk contains an example of phased building - a virtual 3D house. Look in the directory *ISB*\Scenes\Phases for files Phase1-6.wrl. These scenes illustrate the process of building a virtual home. The final project is presented in the main Scenes gallery with the name Los Gatos. Phases 1 to 6 show the structure as it gets more and more complex by adding more faces to the frozen part of the scene. More cameras are added for viewing the scene, and later one object is added as an example of a mobile part of the scene. Look at the phases for a better understanding of the scene building concept.

### Related topics:

- Main scene parts
- Frozen part of scene description and example
- Structured Scene description and example

## Basic Operations

### Creating, Opening and Saving 3D Scenes

#### Create a new scene

To create a new scene:

-  Click New on the Standard toolbar or choose New from the File menu. A new scene is created. All its parameters, such as camera position, grid spacing, etc. are set by default.

You can specify landscape, background colors and panorama images for a new scene.

To set these properties for a new scene:

- 1 Choose Set Background command on the File menu. A dialog box appears.
- 2 Choose the background scheme from a list of available schemes. Select what items: background colors, textures, and landscape from the scheme will be used in the scene you are creating.
- 3 Edit the Ground and Sky colors, if necessary.

### Note:

You can change the background settings for any existing scene at any time you like. The background settings are saved in the scene file and will be shown while viewing the scene by VRML 2.0 browser.

#### Open an existing scene

You can open a scene from a file or choose one from the Scene gallery.

To open a scene from a specified file:

-  Click the Open button on the Standard toolbar or choose Open from the File menu. A new scene is opened and is shown in the Perspective View window. The plan is displayed in the Plan window.

### Note:

The following formats are supported: VRML 2.0 and MUS (the Virtual Home Space Builder format). If a scene in the VRML 2.0 format contains data on a camera's position, it is placed in this position or at the scene coordinate system origin by default. The scene in the MUS format does not contain information on the camera's position, and the camera assumes the default position.

To choose a scene from the Scene gallery:

- 1  Click the Choose button on the Standard toolbar or select Choose from the File menu. The Scene gallery is displayed.
- 2 Look through the gallery to find the required scene.
- 3 Double-click the desired scene or drag it to the Plan or Perspective View window. The scene is opened and is shown in the Perspective View window. Its plan is displayed in the Plan window.

## Save a scene

To save a new, unnamed scene:

- 1  Click the Save button on the Standard toolbar or choose Save from the File menu. A dialog box for the file name appears.
- 2 Specify a file name for your scene.  
To save the scene in other than the default *ISB* Scenes folder, click a different drive name or folder name. For example, if *ISB* is installed in **C:\MSB**, its default scene folder is **C:\MSB\Scenes**. The scenes located in the *ISB* scene folder are automatically included into the Scene gallery. In the File Name box, type a name for the document.
- 3 Select the VRML 2.0 item in the Save as type list box to save the scene in the VRML 2.0 format or choose the VRML 2.0 compressed item to save the scene in the VRML 2.0 compressed (gzip) format. Note that both options create the files with the same extension .wrl. VRML 2.0 browsers automatically identify compressed file format.
- 4 Click Save.

To save an existing scene:

-  Click Save on the Standard toolbar or
- Choose Save on the File menu or
- Drag the scene from the Scene Tree window to the Scene gallery.

## Controlling Camera

### Control cameras

- Cameras are used to view a scene in the Perspective View window. Any number of cameras can be used. Only one camera can be active at any time. A scene is viewed through the active camera. Each camera is represented in the Plan window with the  Pinocchio icon.

In a 3D scene, a camera has six degrees of freedom. You can move it in X, Y, and Z directions. You can also change its orientation:

- Yaw - it appears as if you are turning your head to the left or to the right.
- Pitch - it appears as if you are lifting your head up or drop it down.
- Roll - it appears as if you are inclining your head to the left or to the right.

The camera's movement and orientation are reflected in the Plan window. During the movement and rotation of the active camera, the view in the Perspective View window changes accordingly.



## Navigate cameras in the Plan window

To move a camera along a plan:



- Position the pointer over the Pinocchio icon. The pointer looks like a camera.
- Drag the Pinocchio icon in the desired direction. **Note:**  
You may navigate the camera through walls while moving in the Plan window.

To change a camera's orientation:



- Position the pointer over the Pinocchio icon. The pointer looks like a camera.
- Rotate the Pinocchio icon tip with your mouse (yawing in the Top View window, pitching in the Front View window).

To place a camera in a required position:

- Double-click the desired position in the Plan window. The active camera moves to that location. Its position is changed in the Top and Front View windows.

### See also:

- "Viewing 3D Scenes" example in the *ISB's Quick Start Guide* document.

## Navigate active camera in the Perspective View window

To control the active camera in the Perspective View window:

- Click anywhere in the Perspective View window. Now you can move and rotate the active camera using the mouse or keyboard.

To control the active camera using the mouse in the Scene assembling mode:

- Move the mouse in the desired direction while holding down the left mouse button:

Forward – move closer	Shift+forward – move up	Ctrl+forward - turn up
Backward – move further	Shift+backward – move down	Ctrl+backward - turn down
Right - turn to the right	Shift+right - move to the right	
Left - turn to the left	Shift+left - move to the left	

To control the active camera using the mouse in the Object editing mode:

- Move the mouse in the desired direction while holding down the left mouse button:

Forward/Backward – move camera closer/further to the current object	Shift+forward/Shift+backward - move camera around the object in the vertical plane	Ctrl+forward/Ctrl+backward - turn camera up/down
Right/Left – move camera around the object in the horizontal plane	Shift+right /Shift+left- turn camera to the right/left in the vertical plane	Ctrl+right/Ctrl+left - turn camera to the right/left

- Double-clicking a face in the Perspective View window directs the active camera to the face and brings it closer to the scene.

You can control the active camera using a keyboard commands. *ISB* allows to re-define the keyboard keys assignment for the keyboard navigation. The default assignments in *ISB* are:

- Arrow Up - move closer;
- Arrow Down - move further;
- Arrow Right - move to the right;
- Arrow Left - move to the left;
- PgUp - turn to the right;
- Home - turn to the left;
- Gray Plus - move up;
- Gray Minus - move down;
- 1 on the alphanumeric keyboard - incline to the left;
- 2 on the alphanumeric keyboard - incline to the right;
- 3 on the alphanumeric keyboard - turn up;
- 4 on the alphanumeric keyboard - turn down;
- T - increase a focal length;
- W - decrease a focal length.

To accelerate the camera's movement/rotation:

- Press Shift and one of the above keys simultaneously.

You can make your own key assignments for the keyboard navigation as well as set the velocity and acceleration factor for the keyboard navigation using the Keyboard Navigation dialog box.

**Note:**

You may not move a camera through walls while moving in the Perspective View window while the "collider is on. To turn the collider on/off click Use Collider on the Camera menu. You can also turn the collider on or off by clicking the Collider button on the Camera toolbar.

**See also:**

"Viewing 3D Scenes" example in the *ISB's* Quick Start Guide document.

## Navigate active camera in the Ruler window

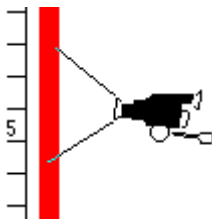

The active camera is controlled in the Ruler window by using the Camera icon.

This icon has a handle with two rings: the left one is used to move the camera, the right one to change the camera's orientation. You can also change the focal length of the camera's view.

To control the active camera in the Ruler window:



- Position the pointer over the Camera icon. The camera picture appears below the pointer.



To move the active camera up or down:

- Drag the Camera icon using the left ring

To turn the active camera up or down:

- Drag the Camera Icon using the right ring.

To change a focal length of the active camera:

-  Click More Tele button on the top of the Ruler window to increase the focal length.
-  Click More Wide button on the top of the Ruler window to decrease the focal length.

**See also:**

- "Viewing 3D Scenes" example in the *ISB's Quick Start Guide* document.

## Align cameras

To position the camera's horizontal axis parallel to the scene horizontal:

-  Click Align Horizontal on the Camera toolbar or choose Align Horizontal on the Camera menu.

To position the camera's longitudinal axis parallel to the scene horizontal:

-  Click Align Vertical on the Camera toolbar or choose Align Vertical on the Camera menu.

## Duplicate cameras

To duplicate a camera do one of the following:

- Double-click the camera icon in the Plan window.
-  Click Duplicate on the Camera toolbar.
- Choose Duplicate on the Camera menu.
- Drag and drop the camera into another object in the Scene Tree window while holding down the Ctrl key.

The new camera has the same location and orientation as the one you've just duplicated.

## Set active camera

To set an active camera do one of the following:

- Click the corresponding Pinocchio icon in the Plan window.
- Double-click the camera name in the Scene Tree window.
- Click the camera tab in the Perspective View window with the name of camera to be activated.

The Pinocchio icon of the active camera is colored red in the Plan window. Its icon in the Scene Tree window is marked with a red box. The camera name in the Perspective View window camera tab is shown in bold font.

## Rename cameras

To rename a camera:

- 1 In the Scene Tree window, right-click the name of the camera you want to rename, and after a pop-up window appears, choose Rename. Or, in the Scene Tree window you can click twice the name of the camera you want to rename. Or, in the Perspective View window you can Double-click

the camera tab. The edit box for the camera name appears.

- 2 Enter the new camera name and press Enter.

**Note:**

The Free camera is assumed to belong to the scene. This camera cannot be removed.

## Delete cameras

To delete a camera:

- 1 Right-click the Pinocchio icon in the Plan window or right-click the camera's name in the Scene Tree window. A pop-up window appears.
- 2 Choose Delete.

**Note:**

The Free camera is assumed to belong to the scene. This camera cannot be renamed.

## Constructing Scene

### Construct scene

*ISB* enables you to build a scene with complex shapes, rather than with individual polygons. A shape is the basic unit for a scene construction. A shape represents a solid object. It can be as simple as a rectangle, or a cone, or it can be as complex as an entire scene. *ISB* allows you to easily manipulate shapes of any size.

The construction process consists of three steps:

- Including a shape into scene. As a result, a draft of the shape is shown in the Top View, Front View and Perspective View windows. The scene is not changed.
- Adjusting shape size, position, and orientation with the help of the Shape Manipulator (see “Set shape position, size and orientation”).
- Applying the shape to the scene using the *Add*, *Extract*, *Cut* or *Copy* operation. When this step is completed, the scene is changed.

A shape may be taken from the Shape gallery or built on the fly.

Related topics:



- Include ready shapes into a scene.
- Include shapes created on the fly.

**TIP:**

You can learn more about building the scenes with the help of “Examples”, given in *ISB*'s Quick Start Guide document.

### Include ready shapes into a scene

To include a ready shape into a scene:

- 1  Click Build Mode on the Plan toolbar. The pointer  looks like an arrow with a hammer near it.

- 

2 Drag the shape into the Top View window. The pointer looks like a shape with an arrow while dragging it.  
Or, you may click the shape in the Shape gallery and draw a bounding box for it in the Plan window.

**Note:**

To draw a box, click anywhere in the Top or Front View window, then hold down the left mouse button, draw a box and release the button.

**TIPS:**

To replace a shape, Double-click another shape in the Shape gallery. You may do this only when a shape is included into, but not yet applied to the scene (Add, Extract, Cut or Copy operations have not yet been made).

A draft shape (on the Plan window but not added yet) is replaced by another one if you draw a new rectangle in the Plan window or accidentally left click there while moving the mouse. This incidental draft shape can be deleted by pressing the Esc key.

## Include shapes created on the fly

You can create shapes on the fly using a polygon or closed curve inscribed into the polygon.

To create a shape using a polygon and to include it into a scene:

- 





1 Click Polygon Mode on the Plan toolbar. The pointer looks like a polygon with an arrow.
- 2 Specify polygon vertexes in the Top View window.  
To specify a vertex, click somewhere in Top View window. A new vertex with edges connecting it to its neighbors is created.



To move a vertex - drag the vertex onto another place.

To insert a new vertex between the existing ones - click between them, the edge connecting the two vertexes is deleted, a new vertex is inserted, and two new edges are created.

To delete a vertex - right-click it and when a pop-up menu appears, click the Delete Vertex item.

- 3 Click either Solid , Walls , Room , or Pyramid  button on the Edit toolbar depending on the shape you want to create. The walls, ceiling and floor have default thickness. To change default thickness, use Options on the Tools menu.





To get an opportunity of using a closed curve include (see "Add of delete toolbar button" for details) the Spline Mode button into the Plan toolbar, and Increase Smoothing, Decrease Smoothing, Increase Tension and Decrease Tension buttons into the Edit toolbar using the Customize item on the Options menu.

To create a shape using a smooth curve and include it into a scene:

- 

1 Click Spline Mode on the Plan toolbar. The pointer looks like a smooth loop.
- 2 Specify polygon vertexes in the Top View window.  
To specify a vertex, click somewhere in the Top View window. A new vertex with edges connecting it to its neighbors is created. The smooth curve inscribed into the polygon is displayed:



- 3 To move a vertex - drag it into another place.  
To insert a new vertex between the existing ones - click between them, the edge connecting the two vertex is deleted, a new vertex is inserted, and two new edges are created.  
To delete a vertex - right-click it and when a pop-up menu appears, click the Delete Vertex item.
- 4 Click either Solid , Walls , Room , or Pyramid  button on the Edit toolbar depending on the shape you want to create. The walls, ceiling and floor have default thickness. To

change default thickness, use Options on the Tools menu.

**TIPS:**

If you want polygon vertexes to snap to the grid cells, complete the following before creating a new shape: Choose Options from the Tools menu. When the dialog box appears click the Plan tab. In the Grid section, mark both the Active grid and Visible grid checkboxes. Choose a ratio to change the coordinate points in the scene plan. For example, a ratio of 1:5 means that the coordinates of any shape's vertex are 1/5th the grid ratio.

To change the curve smoothness:

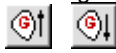

Click the Increase Smoothing or Decrease Smoothing button.

To draw the curve closer to the polygon vertexes:



Click the Increase Tension or Decrease Tension button.

## Set shape position, size and orientation

The following picture shows the Shape Manipulator controls:

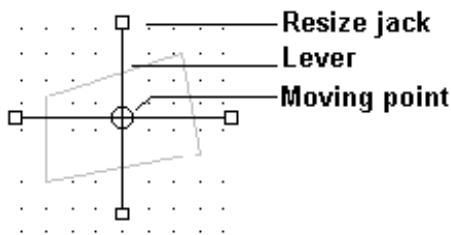

To set a shape position:



- Drag the Shape Manipulator's moving point. The moving point coordinates are seen on the status bar while moving. You can move a shape in any of the three dimensions. Use the top view window to move in the horizontal direction and the front view window to move a shape vertically and along one of the horizontal axes.

To set a shape size:



- Drag the Shape Manipulator's resize jack. Three values that specify the shape's bounding box are shown on the status bar. The first and second values are the coordinates of the bottom left corner of the bounding box. The third value is the bounding box size in the direction defined with the lever. To define a shape's horizontal dimensions, manipulate the top view resize jack. To define a shape's vertical dimensions, manipulate the front view resize jack.

To set a shape orientation:



- Drag the Shape Manipulator's lever. To rotate the box in the horizontal plane, rotate the top view. To rotate (incline) the box in the vertical plane, rotate the front view.

To skew a shape:

- Drag the Shape Manipulator's moving point while holding down the Shift key. The center of the shape's bounding box will drag with your pointer's movements. During deformation the lowest face of the shape at the point it was included into scene remains unchanged, irrespective of shape rotations.

To achieve smooth shape rotation:

- Hold down the Ctrl key while rotating.

To resize a shape in all dimensions at once:

- Press Gray + key on the numeric key pad to increase the size of the shape or Gray - to decrease the size of the shape.

**See also:**

"Simple House" example in the ISB Quick Start guide document.

## Apply shapes to scene

You can use Add, Extract, Cut or Copy operations to apply a shape to a scene. If you define the scene structure using objects, please take into consideration that a shape is applied not to the whole scene but to the current object only.

After part of the scene is brought onto the clipboard using the Cut or Copy operations, it can be pasted elsewhere in any scene.

To add a shape to a scene:

-  Click the Add button on the Edit toolbar or choose Add Shape on the Object menu.

To extract a shape from a scene:

-  Click the Extract button on the Edit toolbar or choose Extract Shape on the Object menu.

To cut part of a scene onto the clipboard:

-  Click the Cut button on the Standard toolbar or choose Cut on the Edit menu.

To copy part of a scene onto the clipboard:

-  Click the Copy button on the Standard toolbar or choose Copy on the Edit menu

**Note:**

The Extract, Cut and Copy operations are unavailable for the Room and Wall shapes, and for non-convex shapes created with the Record Shape command of the Tools menu.

To paste an object previously placed onto the clipboard, do one of the following:

-  To paste it in the position, from which you have placed the item onto the clipboard before, click the Paste button on the Standard toolbar or choose Paste on the Edit menu.
- To paste it on a particular face of any item in the scene, right-click the face in the Perspective View or Plan window. After the pop-up window appears, choose Paste.

## Controlling Shape Heights

### Control shape heights

Each shape you include into a scene is assigned a default size and position. You define default height using the guide lines of the Front View window. After a shape is included you can change its position and size with the help of the Shape Manipulator. The top view Shape Manipulator is used to control the shape's horizontal dimensions and position while the front view Shape Manipulator is used to control the shape's vertical dimensions and position.

If you have an experience of constructing scenes with VHSB and prefer to work without the front view, you can use the Ruler window (). Here you control the height and vertical position of a shape with the help of the Ruler's laths and Guide lines shown in the Ruler window.

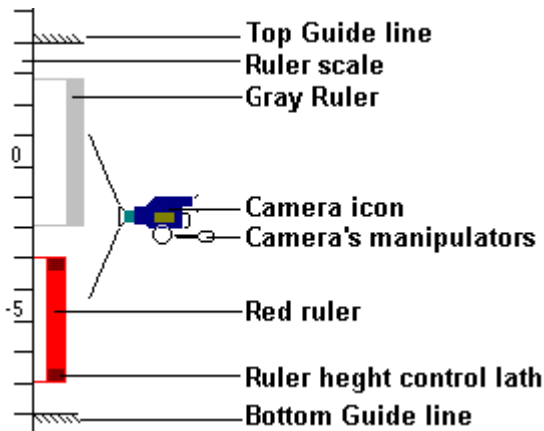

**Top Guide line.** It defines the vertical position of the top face of the shape bounding box when included into the scene.

**Ruler scale.** Shows the camera and objects vertical position in meters.

**Gray Ruler.** Corresponds to the shape currently included into a scene but not yet applied. With the help of the gray Ruler, you can set the height for this shape.

**Camera Icon.** Shows the vertical position and orientation of the current camera in the Ruler window.

**Camera's manipulators.** To move the active camera up or down, drag the Camera icon using the left ring. To turn the active camera up or down, drag the Camera Icon using the right ring.

**Red Ruler.** Corresponds to the current scene object. With the help of the red Ruler, you can change the height of the current object.

**Ruler height control lath.** The top and bottom laths of the Ruler define the position of the top and bottom faces of the shape or object bounding box.

**Bottom Guide line.** It defines the vertical position of the bottom face of the shape bounding box when included into the scene.

To turn the Ruler window on/off:

-  Click Ruler on the Plan toolbar. The Ruler window is displayed when the Ruler button is pressed. The Ruler window is hidden if the Ruler button is not pressed.

## Set shape's default height

The default height of a shape (when included into the scene) is set using the Guide lines shown in the Front View and in the Ruler window. The top guide line defines the vertical position of the top face of the shape bounding box. The bottom guide line defines the vertical position of the bottom face of the shape bounding box.

To turn Guide on/off:

- 1 Right-click anywhere in the Plan window. A pop-up menu appears.
- 2 Check Guide to turn the Guide on or clear it to turn the Guide off.

To see the guide line height and the distance between the two guides:



- 1 Position the pointer over the guide line for a height description. A guide line crossed with a double arrow appears near the pointer.
- 2 Click the line. Its height and the distance between the two guides are shown on the status bar. All values are given in meters.

To move a guide line:





- 1 Position the pointer over the guide line to be moved. A guide line crossed with a double arrow appears near the pointer.
- 2 Drag the guide line up or down. The line's height and the distance between the two guides are shown on the status bar. All values are given in meters.

## Change shape heights

Two Rulers can be shown in the Ruler window:

- The gray Ruler corresponds to the shape currently included into a scene but not yet applied. With the help of the gray Ruler you can set the height for this not yet applied shape.
- The red Ruler corresponds to the current scene object. With the help of the red Ruler you can change the height of the current object.

The top lath of the gray Ruler defines the position of the top face of the shape bounding box. The bottom lath of the Ruler defines the position of the bottom face of the shape bounding box.

To move the Ruler's laths:



- Position the pointer over the lath. The pointer looks like an arrow and a hammer.
- Drag the lath up or down.



## Scroll the Ruler

There are two ways to scroll the ruler: You may scroll the Ruler smoothly or move it by half a point.

To scroll the Ruler smoothly:

- Hold down the left mouse button somewhere in the Ruler window and drag it up or down. The Ruler is scrolled in this direction.

To scroll the Ruler by half a point:

- Click Scroll Up  in the Ruler window to scroll the Ruler up, or click Scroll Down  to scroll it down. The Ruler is scrolled by half a point in the desired direction.

## Creating New Shapes

### Create custom shapes

*ISB* can remember the steps made during a scene construction and repeat them to create a custom shape in the Shape gallery. You can construct a new shape using ready made shapes from the Shape gallery or from shapes built on the fly.

To record and create a custom shape:



- 1 Choose Record Shape from the Tools menu. The pointer looks like a cassette tape with a hammer and an arrow.
- 2 Create a custom shape.
- 3 Choose Stop from the Tools menu. The sequence of operations between the Record Shape and Stop commands is retained. The dialog box for custom shape specification appears.
- 4 In the field Name specify the name of the file for the new shape.
- 5 In the field Title specify the gallery name of the shape.
- 6 In the field Category specify the name of the tab in the Shape gallery where you want to save your shape. You can define a new tab name or use the existing one.

**Note:**

While recording the shape you are actually recording the macro sequence of commands for its creation. So when you apply the recorded shape to the scene the result is the reproduction of all actions you made while recording, including Extract operations with large shapes. This may affect surrounding shape items.

## Manipulating Plan

### Split the Plan window

To split the Plan window when it shows the Top View only:



- 1 Position the pointer over the splitting box in the upper right corner of the top view. The pointer looks like a double line with two arrows.
- 2 Drag down the splitting box. The Plan window is spliced, and the front view window is displayed.

To change the Plan window splitting:



- 1 Position the pointer over the splitting line of the Plan window. The pointer looks like a double line with two arrows.
- 2 Drag the splitting line up to make Top View smaller and Front View larger or drag it down to make Top View larger and Front View smaller.

### Turn the Grid on/off

The Grid is shown in the Plan window by default.

To turn the Grid on/off:

- 1 Right-click anywhere in the Plan window. A pop-up menu appears.
- 2 Check Grid to turn the Grid on or clear it to turn the Grid off.

### Rotate a plan



The scene plan contains only two views: the top view and front view. While constructing a scene, it is sometimes necessary to adjust the direction of the axis for the plan projection we call the front view. *ISB* allows rotation of this axis at any angle in the horizontal plane of a scene. To rotate the plan, use the Plan wheel shown on the bottom of the Plan window. The top view plan rotates, while the front view plan changes depending on a change in the direction of its projection axis. You can rotate the Plan wheel with your pointing device. The rotation angle is shown on the status bar. Each point of the Plan wheel is equal to 6 degrees. Rotation of the wheel to the next longer mark corresponds to a rotation by 30 degrees. Rotation of the wheel to the next bold mark corresponds to a rotation by 90 degrees.

To rotate a plan:

- 1 Position the pointer to the Plan wheel, then hold down the left mouse button.
- 2 Rotate the Plan wheel by moving your mouse in the opposite direction desired to rotate the plan. For example, for the left plan view, rotate the Plan wheel to the right until its next black mark fits the red triangle.
- 3 Release the mouse button.

**Notes:**

- To get a smooth rotation, hold down the Ctrl key while moving the mouse.
- The coordinate grid does not change as you change the projection axis of the plan rotation. A new



draft shape will be oriented towards the axis of the coordinate grid, not the plan rotation and appears turned to the same angle as the projection axis. Therefore, to turn the shape precisely to a specified angle on the top view, you can first turn the plan with the wheel, include the draft shape into it, and then restore the rotation angle to the initial position.

- To restore the plan and Plan wheel initial positions:  
Double-click the wheel. The rotation angle shown on the status bar is equal to zero.

## Scroll a plan (pan the view port)

Besides scrolling a plan using the ordinary scroll bars of the Plan window you may also use the Moving Plan mode. In this mode both views are scrolled at once by moving your mouse.

To move plan views:

- 1  Click Moving Plan on the Plan toolbar.
- 2  Position the pointer anywhere on the Plan window. The pointer looks like an arrow with a hand below it.
- 3 Hold down the left mouse button and move the mouse in the direction desired. Both plan views are moved simultaneously.
- 4 Release the mouse button. The Moving Plan mode is turned off. The Build mode is restored.

## Zoom of plan



To increase view magnification:

-  Click Zoom In on the Plan toolbar. The two plan views magnification is increased.

To reduce view magnification:

-  Click Zoom Out on the Plan toolbar. The two plan views magnification is reduced.

To magnify a selected part of a plan:

-  Click Zoom Mode on the Plan toolbar to turn on the Zoom mode. In this mode you can select a particular area in the top or front view to zoom in on.
-  Select an area to zoom in on. To select an area, hold the left mouse button anywhere in the Plan window, draw a corresponding rectangle, then release the button. The area is immediately magnified in both views.

**Note:**

The grid can be hidden as a result of zooming.

## Fit a window to a scene

To make both scene views fully visible in the Plan window:

-  Click Fit to Scene on the Plan toolbar.

**Notes:**

- If only one view is displayed then only that view is fitted to the window. The scene may not fit in the other view when it becomes visible.
- The rectangle parallelepiped includes all scene parts as well as cameras. Its dimensions are taken as the overall scene size on the plan. Therefore, the plan's scale is set so that all elements of the scene can be seen.

## Print a plan

To print both plan views:

-  Click Print on the Standard toolbar or choose Print on the File menu.

**Note:**

- The printer output should look the same as the current Plan Window configuration, including the presence and relative size of top and front views.

## Using Shapes in the Perspective View Window

### Placing shapes in the Perspective View window

When you include shape into the scene by dragging it in the Plan window a gray semi-transparent shape appears also in the Perspective View window. This allows you to adjust the shape position relative to the items directly in 3D space. You can also include a shape into the scene by dragging it directly in the Perspective View window:

- 1 Position the camera to make visible an item already present in the scene.



- 2  Prism6 Click the shape you would like to apply to scene and drag it in the Perspective View window. The pointer looks like an arrow with the shape icon and name near it.



- 3 Position the pointer on the face, on which you decide to place the shape. If you point to the empty space the pointer shows that including shape operation is not available.
- 4 Release the mouse button. The shape is placed exactly onto the face of visible item in the Perspective view window. All shapes in the Shape gallery have one face, marked as its bottom face. When you drag the shape onto the face in the Perspective View window it is automatically positioned to “touch the target face by its own bottom face. This is useful if you decide to apply the shape to the existing scene and position it exactly on the ground landscape (for details, see “Scene background schemes: overview”) surface.

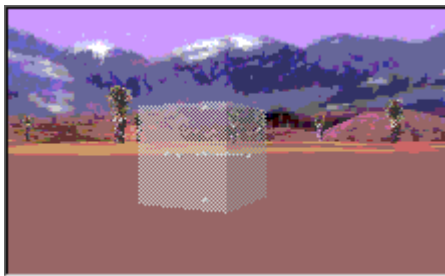

The picture to the left illustrates the shape, included into the scene with Desert background scheme as a first step of building a house. The bottom face of the shape is only touching the ground surface, but not going through it. You can change the shape size, position and orientation using the Shape manipulator in the Plan window or using Shape manipulator in the Perspective View window.

**Note:**

- All shapes in the Shape gallery have some face, defined as bottom face. Even Sphere shapes have their bottom faces. This allows setting of complex shapes, like the sphere, onto the face in 3D space in the same way as for the other shapes.

## Set shape position, size and orientation in the Perspective View window

When you include shape into the scene by dragging it in the Plan or Perspective View window it is shown in as gray semi-transparent shape in the Perspective View window:

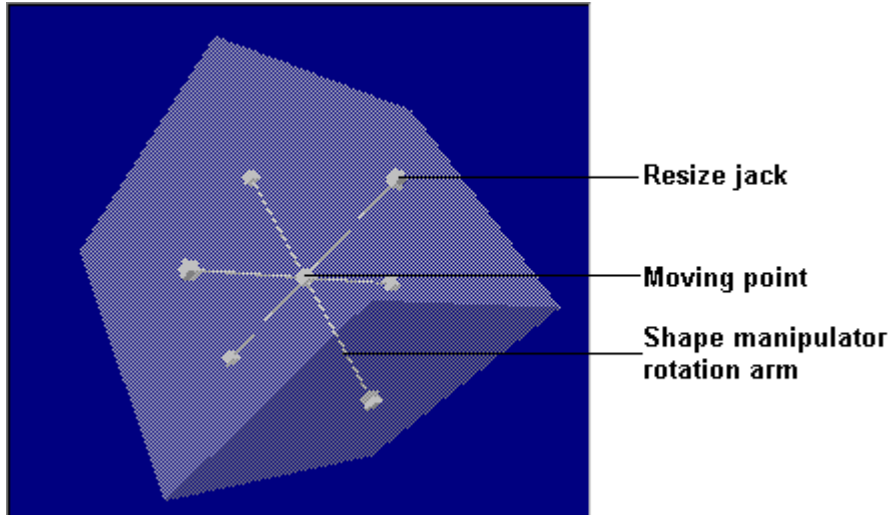

### Resize jack

Drag this point to change the shape's size in the direction, defined by the manipulator arm.  
Shape manipulator rotation arm

### Moving point

Drag this point to move the shape to another place in 3D space. The shape moves in the plane, parallel to the Perspective View window plane.

### Shape manipulator rotation arm

Drag this arm to turn the shape. The shape is turned around one of the other arms. The rotation axis is set automatically according to the direction of first pointer's motion.

You can adjust the shape position, size and orientation relative to the items directly in 3D space Using the Shape manipulator in the Perspective View window. The picture above illustrates the Shape included into the scene and its Shape manipulator.

Several rules are applied while you change the shape dimensions or position using the Shape manipulator in the Perspective View window:

- While you move the shape, it always moves in the plane, parallel to the Perspective View window plane. In other words, if you change the camera orientation you also change the shape motion plane orientation.
- While you resize the shape it grows/shrinks so, that its bound box, opposite to the resize jack you are currently dragging keeps its position. This ensures that after you have placed the shape onto the face it remains exactly touching the face while you resize the shape dragging its resize jacks, not located on its bottom face.
- You can choose the rotation axis while rotating the shape in the Perspective View window by making the first mouse movement very carefully and choosing its direction looking parallel in three dimensional space to the Shape manipulator arm, around which you do not want to rotate it. This sounds little bit confusing, however you can get good practice after several attempts.

### TIP:

To make setting the shape position and orientation easier, always try to set the camera viewing position to make all Shape manipulator arms displayed in the Perspective View window going in as much as possible different directions. The example of suitable camera viewing position is given on the picture above.

## ISB Limits

Several restrictions exist regarding the size of scenes, shapes, and objects, and the scale of a plan.

Maximum size of a scene: 1000 m (1km).

Minimum size of a shape or object: 0.01m (1cm).

Minimum scale of a plan: 0.001 m/pixel (1mm/pixel).

Maximum scale of a plan: 10m/pixel.

## Scene Background and Landscape

### Scene background schemes: overview

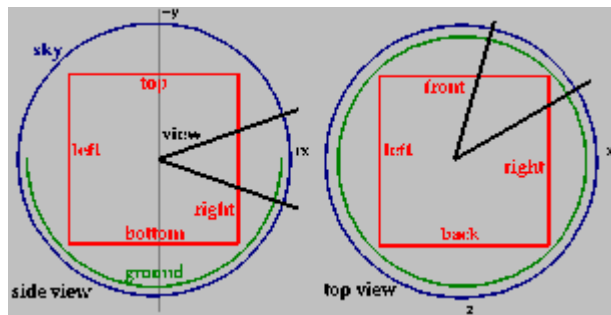

Each scene you are creating or editing may contain background color, background texture images and landscape. Combinations of these three components are grouped in several background schemes. You can chose to apply to your scene any component from any background scheme.

- Background color.** Background color is used to paint the scene background with colors to simulate the sky and the ground colors. The background color is displayed as if the camera is located in the center of a very large sphere. The sphere is always moving together with the camera keeping it in the center, so you can not come close to the sphere. The sphere is painted with color circles, each circle is defined by the angle from the Zenith (straight up) viewing direction. You can specify the color for each angle value. The color of rings between the specified angles is changing gradually (interpolated). For example, to simulate the sunset sky color you can set the zenith color as dark blue and the horizontal plane color and red. The sky sphere color will change gradually from red to blue while you are looking higher and higher turning the camera up. You can specify the sky color for the angles below the horizon down to the Nadir (straight down) viewing direction. This is useful when you are building the scene without ground, e.g. open space. For the scenes containing ground you also can specify the ground half-sphere color. If the ground color is specified, the background colors below the horizontal plane are shown according to the ground color settings and the sky colors are ignored. There is sharp horizontal border between the sky and the ground. The picture above, taken from the VRML 2.0 language description, illustrates the background color settings.
- Background textures.** When you use the background colors you always get the same color when you turn the camera around the vertical axis. To simulate the natural sunset you have to specify the scene background images for different viewing directions. In *ISB* you can apply textures to faces of very large cube, inscribed into the sky sphere as shown on the picture above. The cube is always moving together with the camera keeping it in the center, so you can not come close to the cube face. The textures are prepared in a special manner eliminating the visibility of borders between the cube faces and producing the effect of a sphere with an image on it. If a transparent color is used in the texture then the sky and ground colors are also visible through the texture image. The combination of background color and background textures allows to create sophisticated and impressive Scene backgrounds.

- **Landscape.** The scene may contain not only the background but a landscape. Landscape simulates the ground relief and may be flat as well as imitate mountains. You can choose the landscape from a set of available landscapes from any background scheme delivered with *ISB*. You can not edit the landscape. However you can place scene items on the landscape surface and apply texture to the landscape. All landscape surface is treated as a single face, so when you apply a texture all landscape is textured as a whole. The texture image is stretched to apply to the whole landscape without tiling by default. You can map the textures applied to the landscape using texture mapping operations.

**See also:**

“Using Background schemes” example in the ISB Quick Start Guide document.

## Setting the scene background and landscape scheme

You can set the background properties scheme for any scene you are editing. After you have set the background scheme, you can change it at any time.

To set and edit the scene background scheme:

- Choose Set Background on the File menu. A dialog box shown on the picture below appears.

In this dialog box you can:

- Choose the background scheme from a list of available schemes
- Select which components of the scheme will be used in your scheme
- Set the current scheme as default background scheme for all new scenes in *ISB*
- Edit the background colors for the sky color and the ground color
- Preview the results of editing the background in the Preview section of the dialog box
- Apply the editing operations to the current scene

The following explains all controls in the Background dialog box:

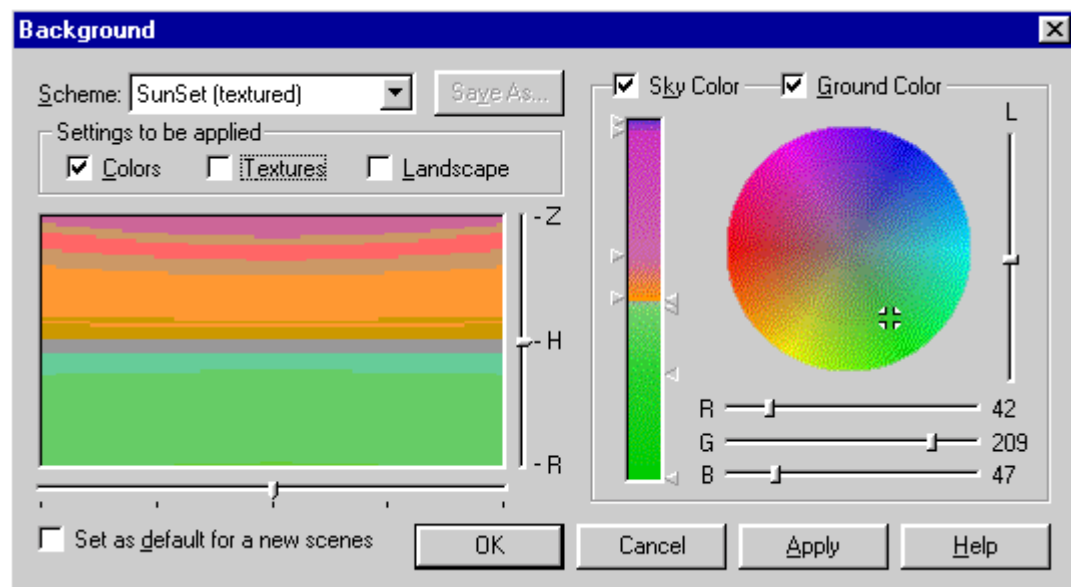

**Background Scheme.** Select the background scheme from a list of available schemes.

**Save as button.** Click this button to open standard Save As dialog to save the background scheme you have created under a new name.

**Sky color.** Check this item to edit the Sky color. You can set the sky color for every angle above and below the horizon. Note that if the Ground color item is checked the sky color below the horizon is not visible.

**Ground Color.** Check this item to edit the Ground color. You can set the sky color for every angle below the horizon.

**Settings to be applied area.** You can apply the scheme settings for Colors, Textures and Landscape in this area.

- **Colors.** Place mark near this item to replace the current Scene background colors with colors, specified in the new scheme. If this item is not checked, the colors from the new scheme do not substitute the current colors.
- **Textures.** Place mark near this item to replace the current Scene background textures with textures, specified in the new scheme. If this item is not checked, the textures from the new scheme do not substitute the current textures.
- **Landscape.** Place mark near this item to replace the current Scene landscape with the landscape, specified in the new scheme. If this item is not checked, the landscape from the new scheme does not substitute the current landscape.

**Preview background window.** You can preview the scene background in this window. While viewing you can turn the camera in vertical and horizontal planes to observe the background for any viewing direction.

To turn the camera in the vertical plane:

- Drag the Vertical rotation slider control located to the right from the Preview window, or
- Click anywhere in the window and move the mouse pointer vertically, holding down the left mouse button.

**Vertical rotation slider control.** Move this slider to turn the camera in the preview window in the vertical plane. The top of the slider, marked with Z character corresponds to zenith (straight up) viewing direction, the middle of the slider - to horizontal viewing direction and the bottom mark N - to the nadir (straight down) viewing direction.

**Horizontal rotation slider control.** Move this slider to turn the camera in the preview window around the vertical axis. The middle mark of the slider corresponds to the forward viewing direction while the edge marks of the control correspond to the backward direction. The marks to the left and to the right from the middle mark correspond to 90 degrees rotation angle to the left and to the right, respectively.

**Color distribution bar.** This bar shows the background color distribution from zenith (top of the bar) to nadir (bottom of the bar) with the horizon color in the middle of the bar. You can change the color for any angle by placing the mark near the bar and setting the color in the Color Control circle. The color for the angles between the marks is changing gradually (interpolated).

**Sky angle marks area (on the left from the Color distribution bar)**

- Click anywhere in this area to place an angle mark for the sky sphere color near the Color distribution bar. The top of the bar corresponds to the zenith (straight up camera viewing direction), the middle point of the bar - to the horizontal viewing direction and the bottom of the bar - to the nadir (straight down viewing direction).
- Set the color value in the Color Control circle. The color for the angles between the marks is changing gradually (interpolated).



After you have specified the angle mark, you can change the angle value by dragging the mark up and down over the angle marks area. To remove a mark, drag it outside the angle marks area. Click the angle mark to make it active. Active angle mark is displayed as depressed.

**Ground angle marks area**

- Click anywhere in this area to place an angle mark for the ground semi-sphere color near the Color distribution bar. The middle of the bar corresponds to the horizontal viewing direction and the bottom of the bar - to the nadir (straight down viewing direction).
- Set the color value in the Color Control circle. The color for the angles between the marks is changing gradually (interpolated).

After you have specified the angle mark, you can change the angle value by dragging the mark up and down over angle marks area. To remove a mark, drag it outside the slider control. You can not set the ground angle value over the horizon. Click the angle mark to make it active. Active angle mark is displayed as depressed.

**Color Control circle.** Click anywhere in this circle to set the color value for the current active angle mark. Luminosity and RGB values of the color are shown near the Luminosity and RGB slider controls.

**Luminosity control slider.** Use this slider control to set the luminosity of the color. The changes in luminosity are reflected in the Color control area.

**RGB slider controls.** Use these control sliders to set the RGB values for the color. The numeric values are displayed to the right of each slider control. Color settings are shown by a cross mark in the Color control area above the sliders.

**Set as default for a new scene.** If this item is marked the background scheme you have specified will always be used when you start editing a new scene. Remove mark if want to use the background scheme only for the scene you are currently editing.

**OK button.** Click this button to apply the background settings to the Scene and close the dialog box.

**Cancel button.** Click this button to cancel all editing operations and close the dialog box.

**Apply button.** Click this button to apply editing operations without closing the dialog box.

**Related topics:**

- Scene background schemes: overview
- Editing Background colors

## Editing Background colors

Background color is used to paint the scene background with colors to simulate the sky and the ground colors. Background color is a part of Scene Background scheme, containing also Background Textures and Landscape components. You can use the background from any background scheme or edit the background colors by yourself and save new settings as a new scheme.

To start choosing or editing the Background Colors:

- Choose Set Background command on the File menu. A dialog box for setting the Scene background properties appears.

To choose the Background Color from a scheme:

- 1  Click the drop down button to open the list of available Background schemes.
- 2 Click the name of the scheme you like to use in your Scene.
- 3 Place a mark in the Colors checkbox and remove a mark in the Textures checkbox to make the current scheme Background Color visible in the preview window below.
- 4 Preview the Background Colors arrangement by changing the camera viewing direction while dragging the image in the preview window up and down to turn the camera vertically. You can use the slider to the right of the preview window to control the camera orientation. The top slider position corresponds to the Zenith (straight up) viewing direction, while the bottom slider position corresponds to the Nadir (straight down) viewing direction. The middle slider position corresponds to horizontal camera orientation.
- 5 Click the Apply button to apply the settings to the Scene you are editing.

To edit the Background Colors arrangement:

- 1 Choose the Background Color from any available scheme to use it as a starting point for editing.
- 2 Place or remove marks in the Sky Color and Ground Color checkboxes to enable or disable the corresponding Background Color settings.
- 3 To set the sky color for some angle:
  - Make sure the Sky Color checkbox is marked.
  - Click anywhere in the area to the left from the Color distribution bar. A mark appears, which corresponds to some angle value. The mark becomes active which is indicated by displaying it as depressed. You can move the mark up and down by dragging it with the mouse. You can activate existing mark by clicking it with your mouse.
  - Specify the color for the active mark in the color selection circle. For this, click the point with desired color within the circle. You can also adjust the RGB and Luminosity values manually while moving the corresponding slider controls.
- 4 To set the Ground Color:
  - Make sure the Ground Color checkbox is marked.
  - Click anywhere in the area to the Right from the Color distribution bar. Note, that you can specify an angle mark for the Ground color only for the angles below the horizon.
  - Specify the color for the active angle mark in the way, similar to the Sky color settings. Note, that when the Ground color is enabled, the colors for the directions below the horizon are following the Ground color setting, which is shown both in the Color Distribution bar and the Preview window.
- 5 Rearrange existing angle marks and set their colors to create the desired Background color for your Scene. You can remove the marks you have created accidentally or those you do not need by dragging the marks outside from the angle marks area. View the Background color arrangement in the preview window.
- 6 After you finished editing the color arrangement you can apply settings to your Scene by clicking the Apply button.

You can save the Background color setting together with Textures and landscape as a new Background scheme in a file. You can load this scheme later and use it with any other scenes.

To save the Background scheme:

- Click Save As button and specify a filename in the standard File Save dialog box.

## Using Colors and Textures

### Setting the Face Material properties: overview

Each face created in the scene may have material properties. In *ISB* you can set the following material properties of a face:

- **Color.** You can specify any color for any face in the scene. The whole face becomes colored. The actual face color displayed in the Perspective View window depends on the face orientation relative to the scene light source. Thus some faces having the same color may appear lighter or darker. You can not set the light source parameters in *ISB*.
- **Texture.** You can apply an image pattern to any face in the scene. The whole face is textured (decorated) with the texture image. The image patterns are repeated (tiled) along the face. Thus if you apply a single small brick image to the face, the whole face is looking like a brick wall. The face color is hidden under a texture image.
- **Transparency.** You can set transparency value of a face. For example, if you set 50% transparency to a face, it becomes semi-transparent and you can see both its material and the items behind the face in the Perspective View window. Setting the transparency value to 100% makes the face invisible. By specifying the face transparency you can imitate the glass material for windows and similar scene items.
- **Texture mapping.** While making the face imitating the brick wall you may need to change the period of brick images repetition along the wall to make the whole face fitting the integer numbers of bricks along both horizontal and vertical directions. You may also want to turn or shift the texture image pattern applied to the specific face to make it better fitting the face borders and orientation. These operations as well as some more complex texture transformations are similar to drawing the Earth map on the Globe.
- **Texture animation.** You can specify texture motion along any face in the scene and set the motion speed and direction in *ISB*. Animated (moving ) textures are useful if you, for example, want to show the water motion in a river or lake as well as moving clouds in the sky.

Every new face, created in the scene as a result of editing operations with shapes has material properties shown in the Material Preview window , located by default at the bottom left corner of the *ISB* screen in the Screen\_Layout .

When you start *ISB* the following default material is used:

- **Color** - 50% gray.
- **Texture** - none.
- **Transparency** - zero. The face is not transparent.
- **Texture mapping** - default tiling values, specified in the Tools/Options/Texture Mapping dialog will be used when you apply a texture to a face, created earlier without a texture. Texture image is applied non distorted, except its size along the vertical and horizontal texture image directions.
- **Texture animation** - none. When you apply a texture to a face, created earlier without a texture, the texture image does not move along the face.

## Using face materials

The following options are supported:

- The face material is automatically applied to all faces in the scene, created as a result of scene editing operations with shapes.
- The material any face a scene item can be changed anytime.
- Material properties can be spread from one face to others.

The textures for the face material are selected from the Texture gallery, the colors are selected from the Material bar.

To display the Texture gallery:

- Place a mark near the Textures item on the View menu.

To display the Material bar:

- Double-click the Material Preview window to open the Material bar.

To specify a texture of the material:

- Drag the texture onto the Material Preview window at the top of the Material bar.

To set a color of the material:

- Click the color you like in the Color control circle and then drag the Luminosity slider to set the luminosity value of the color.

To set transparency value for the material:

- Drag the Transparency slider, located to the right from the Luminosity slider.

To reset all material parameters to default values:

- Right-click the Material Preview window and choose Reset on the pop-up menu.

**TIP:**

To learn how to use colors and textures, read “Decorating the scene” example in the *ISB's Quick Start Guide* document.

## Applying default material to faces

When you add a new shape to the scene, the current material from the Material bar is automatically applied to all new faces. If a shape was added to a scene, the material is applied to the faces that are not absorbed by other shapes in the scene. When a shape is extracted, all new faces formed as a result of withdrawing a portion of the scene have the material properties specified in the Material bar.

## Material Bar

Current material properties are displayed in this window on a sample sphere. You can open the Material bar in full size by Double-clicking the Material Preview window.

**Go to Face.** Moves the camera to the position suitable for viewing the face in full size in the Perspective View window.

**Clear Texture.** Removes the texture together with its mapping information from the current set of material properties in the Material bar.

**Stop texture.** Stops the texture animation for the current material in the Material bar.

**Material Preview window.** You can preview the face material on the sample sphere in this window.

**Luminosity control slider.** Use this slider control to set the luminosity of the color. The changes in luminosity are reflected in the Color control area.

**Transparency control slider.** Defines the transparency value of the current material.

**Color Cells.** Shows the basic colors available. To define a custom color, Double-click the color cell to open Color dialog box.

**Moving Texture.** This is the texture animation control of the Material bar. It is used to create moving textures.

To animate the current texture:

- 1 Drag the central green circle in the direction of the texture motion.
- 2 The red arm of the animation control is displayed. A longer arm means faster motion. The direction of the texture motion is defined with arm direction.

To stop animation:

-  Click the Stop button on the toolbar at the top of the Material bar.

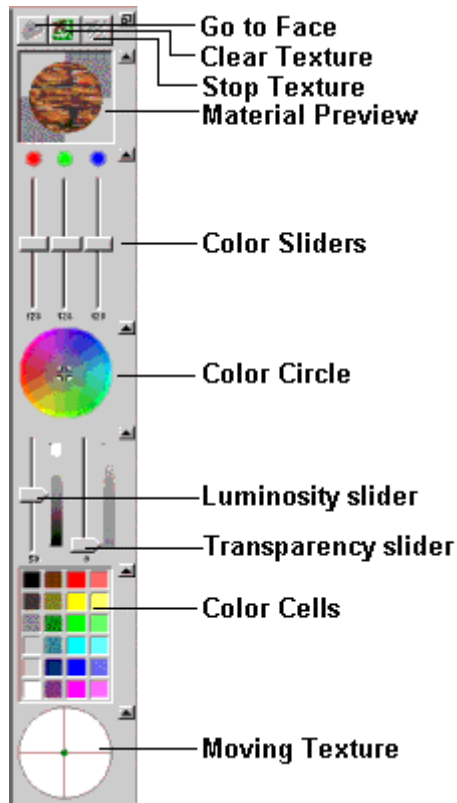



## Apply textures

You can apply the texture from the Texture gallery to any face in the scene.

To texture a face:

- 1 Look for the texture you want in the Texture gallery. To open another texture category, click its tab on the tab strip of the Texture gallery window.
- 2 Drag the texture to the face in the Perspective View window.

To texture all faces of the object simultaneously:

- 1 Look for the texture you want in the Texture gallery. To open another texture category, click its tab on the tab strip of the Texture gallery window.
- 2 Drag the texture to the Material Preview window.
- 3  Click Fill on the Brush toolbar.
- 4  Move the pointer into the Perspective View window. It looks like a pail.
- 5 To texture only one face, click the face in the Perspective View window. The face is textured.
- 6 To texture the whole object Double-click any of its faces. The current texture from the Material bar

will be applied to all the faces of a frozen part of the object (scene) to which this face belongs.

**Notes:**

- Fill and Spread operations always apply all material properties to the face. Thus texture mapping information, face color under the texture, transparency value, and texture animation are also applied to the face.
- Using the Fill and Spread operation, a face material can be spread without skipping over the blank space or volume the part itself occupies. If there is a closed cavity inside a figure (the inner part of it is cut out), its external and internal faces are filled by material independently.
- By Double-clicking a face, a face material is applied to all the faces of the frozen part of the scene or current object. All other objects including its sub-objects are not changed. For example, if there are two separate objects in a scene, the material will only be applied to the faces of the double-clicked object.
- If two isolated parts in a scene (object) are visually interconnected with a part belonging to another object, they are not considered interconnected in the sense of face material transfers.



## Setting face colors

To set a default face color under the texture:

- 1 Make sure that the Material bar is displayed.
- 2 Click the color you like in the Color control circle and then drag the Luminosity slider to set the luminosity value of the color.

The color you have specified will be applied as a component of material properties to all new faces created in the scene as a result of operations with shapes.

To color one or all faces of the object simultaneously:



- 1 Make sure that the texture is not specified in the Material bar.
- 2  Click Fill on the Brush toolbar.
- 3 Click the color you like in the Color control circle and then drag the Luminosity slider to set the luminosity value of the color.
- 4  Move the pointer into the Perspective View window. It looks like a pail.
- 5 To color one face, click it in the Perspective View window. The face acquires the current color from the Material bar. To color all the faces of frozen part of the scene (object), Double-click any of its faces. All the faces of the frozen part of the object (scene), to which this face belongs, will acquire the current color.

**Note:**

When an object is painted, all other objects including its sub-objects are not changed.

## Spreading materials

To spread a face material properties from one face to the others:

- 1  Click the Spread button on the Brush toolbar.
- 2  Position the pointer over the face with the required material properties in the Perspective View window. The pointer looks like a brush.
- 3 Hold the left mouse button.
- 4 Drag the material through all faces to be applied.

To spread a texture or color over the whole object:

- 1  Click Spread on the Brush toolbar.

-  Position the pointer over the face with the required texture or color in the Perspective View window. The pointer looks like a brush.
- Double-click the face - all other faces of the object are textured or colored.

**Notes:**

- Transfer of material from a face of one object to the faces of other objects is impossible.
- Material transfer across parts, from one face to another, is impossible if there is any empty space, even if the two parts belong to the same object (scene).
- Using the Fill and Spread operation, a face material can be spread without skipping over the blank space or volume the part itself occupies. If there is a closed cavity inside a figure (the inner part of it is cut out), its external and internal faces are filled by material independently.
- By Double-clicking a face, a face material is applied to all the faces of the frozen part of the scene or current object. All other objects including its sub-objects are not changed. For example, if there are two separate objects in a scene, the material will only be applied to the faces of the double-clicked object.
- If two isolated parts in a scene (object) are visually interconnected with a part belonging to another object, they are not considered interconnected in the sense of face material transfers.

## Using Pictures and Movies

### Set pictures/movies onto a face

To set a picture/movie onto a face:

- 1 Look for the picture/movie in the Picture/Movie gallery.



- 2 Drag the picture/movie to the face. The pointer looks like a picture/movie with name and an arrow.

**Note:**

Pictures and movies are not shown on the scene plan.

### Specify movies play order

Each movie can be played forward, backward or in turn: forward - backward, forward - backward, etc.

To specify the movie play order:



- 1 Position the pointer over the movie you want in the Perspective View window. The pointer looks like a picture with an arrow.
- 2 Right-click the movie. A pop-up menu appears.
- 3 Click Play order. A pop-up menu with available modes of play appears.
- 4 Click Forward to play the movie in the forward direction, click Backward to play the movie in the backward direction, click Ping Pong to play in turn.

### Copy pictures/movies

You can have several copies of picture/movie in a scene. You can make a copy using the Picture/Movie gallery or by using the Scene Tree window.

To copy a picture/movie using the Picture/Movie gallery:

- Put it into the scene once more.

To copy a picture/movie using the Scene Tree window:

- 1 Look for the picture/movie name in the Scene Tree window.

- 2  Drag the name to the Perspective View window while holding down the Ctrl key. The pointer looks like an arrow with a small picture near it when been dragged over the scene parts where the picture can be placed.

## Change pictures/movies location

You can change a picture/movie location in a scene by dragging it through the Perspective View window or by dragging its name from the Scene Tree window.

To change a picture/movie location using the Perspective View window:

- 1  Position the pointer over the picture/movie in the Perspective View window. The pointer looks like a hand.
- 2 Drag the picture/movie in the direction desired.

To rotate the picture/movie on the face:

- 1  Position the pointer over the picture/movie corner in the Perspective View window, holding down the CTRL key. The pointer looks like circle with two arrows.
- 2 Drag the corner to rotate the picture or movie

To change a picture/movie location using the Scene Tree window:

- 1 Look for the picture/movie name in the Scene Tree window.
- 2  Drag the name to the desired location in the Perspective View window. The pointer appears like an arrow with a small picture near it when being dragged over the scene parts where the picture can be placed.

## Resize pictures/movies

To resize a picture/movie:

- 1  Position the pointer over the corner of the picture/movie in the Perspective View window. The pointer looks like a double arrow.
- 2 Drag the corner of the picture/movie to achieve the desired size.

## Delete pictures/movies

To delete a picture/movie:

- 1  Position the pointer over the picture/movie in the Perspective View window. The pointer looks like a picture with an arrow.
- 2 Right-click the picture/movie. A pop-up menu appears.
- 3 Click Delete. The picture/movie is deleted.



# Advanced Features

## Using Objects

### Use objects

You can take a ready object from the Object gallery or construct your own object entering the Object editing mode. You can also import objects made with Autodesk 3D Studio (see “Import objects”).

### The Scene Tree

The Scene Tree presents the information about a scene structure. The Scene Tree is very similar to a genealogical tree. The Scene Tree root node represents a whole scene. Each tree node represents an object, picture or movie. Each node can have any number of child nodes (sub-objects). Each node, with the exception of the root node, has a parent.

The relations between *ISB* objects are defined in the following way:

- When an object is resized or moved (rotated), all its sub-objects are resized by the same coefficient or moved (rotated) by the same distance (angle).
- If an object is saved to a file or deleted, all its sub-objects are saved or deleted too.
- If the above mentioned operations are applied to a sub-object, they in no way affect its parent object(s).
- Editing (adding and extracting shapes) a frozen part of any object does not affect any other objects.
- Mutual subordination of the objects in a scene can be arbitrarily changed.

#### Notes:

- The scene is your world, and like the real world we can't move, resize, or turn it. This means that there are no Object Manipulators for the scene, and that you may not change its heights using the Ruler. You also cannot apply the Cut, Copy, and Delete operations to the whole scene.
- Pictures and movies appear in the Scene Tree under their gallery names.

## Place Objects into the scene

To place an object from the Object gallery to scene:

- 1 Click a tab in the Object gallery, then scroll the gallery to find the object you need. Repeat this step with other tabs till the object is found.



- 2  Castle Drag the object to the scene with the mouse.

#### Note:

You can drag and drop objects into the Plan, Perspective View and Scene Tree windows:

*Plan window.* The object becomes a child of the current object. It is located in the place where you dropped it. The center of the parallelepiped which defines the object's limits is set on the plan at a point where the mouse button was released while dragging. The third coordinate of the parallelepiped center is, by default, set in the middle of the window of the other view.

*Perspective View window.* An object cannot be inserted into the vacant space of a scene. The object becomes a child of the object associated with the face upon which you drop the object. The object attaches to the face with its own bottom face. This guarantees, for example, that when a chair is placed on the floor, it is directly on the floor, not suspended above it or passing through it.

*Scene Tree window.* The object becomes a child of the object upon which it was dropped. The center of the parallelepiped, which defines the object's limits, is set at the origin of the scene

coordinate system.

Objects placed according to the above methods are eligible for all object operations, such as rotation, resizing, linking URLs, renaming ,etc.

**Note:**

- Object files in the gallery store information about the object's orientation, including the direction of the vertical axis of its coordinates. An object in the gallery is displayed so that its orientation coincides with the orientation it will have when placed into a scene. When dragging an object to a face in the Perspective View window, the object "falls" such that its vertical axis coincides with the target face's normal. Therefore, an object such as a chair oriented in the gallery with its legs downward is always placed on a face with its legs directly touching the face. If an object is turned on its side in the Object Editing mode and then saved to the gallery, it will "lie on its side when placed on the face. Our advice is to keep track of the object orientation before saving it in the gallery, if the notions "top and "bottom make any sense (for example, objects like furniture).

## Working with the Geometry Clipboard Content

You can view and edit the Geometry Clipboard content as if it is an object. *ISB* allows to show the Geometry Clipboard content in a special Clipboard Content window. By default, the Clipboard Content window is shown in the bottom right part of the *ISB* screen in AutoShow mode. In this mode the Clipboard Content window is shown only if the Clipboard is not empty. If you close the Clipboard Content window it will be shown again if the Clipboard content is changed.

To show or hide the Clipboard Content window:

- Place a mark or remove mark near the Clipboard item on the View menu.

To enable or disable the AutoShow mode:

- Right-click the Clipboard Content window to open the pop-up menu. Place a mark or remove mark near the Enable AutoShow item to enable or disable AutoShow mode.

To save the Clipboard content as an object into the Object gallery:

- Choose Save command on the Clipboard Content window pop-up menu. Specify the name of new object and gallery category in the Save Object dialog box.

You can enable or disable clearing of the Clipboard Content immediately, after the next Paste command or when you load new scene:

- Choose Clear Now command on the Clipboard Content window pop-up menu to clear the Clipboard Content immediately
- Place a mark or remove a mark near the Clear After Paste item to enable or disable clearing of the Clipboard Content after the first Paste command. Clearing the Clipboard after the Paste command may help to reduce the memory requirements and improve the *ISB* performance if you do not need to keep the Clipboard Content after you have done the Paste command for a very complex object placed onto the clipboard before.
- Place a mark or remove a mark near the Clear on Scene Reload item to enable or disable clearing the Clipboard Content when you load a new scene in *ISB*. Keeping the Clipboard content while loading another scene is useful for insertion of the Clipboard Content as an object from one scene to another.

You can edit the Clipboard Content as an object in the Object editing mode. To edit the Clipboard Content do one of the following:

- Choose Edit on the Clipboard Content window pop-up menu or
- Double-click the Clipboard Content window.

The Clipboard content is opened in the Object editing mode. After you have finished editing click Scene Plan tab. The object you have created is placed onto the Clipboard.

To insert the Clipboard Content into the scene as a new object:

- Choose Paste command on the Edit menu or
- Click the Paste button on the Standard toolbar or
- Drag the object from the Clipboard Content window on the Plan window or onto any face in the Perspective View window. This operation is completely equivalent to the Drag and Drop operation for the object from the Object gallery.

## Import objects

To import an object from a file in the 3D Studio format and save it into the Object gallery, do the following:

- 1 Choose Import on the Object menu. The standard dialog box for file specification appears.
- 2 In the Save Object dialog box, enter a name which will accompany the object in the Object gallery, and the category to which the imported object will be saved. The data in the 3DS format are converted to the *ISB* format and are written as an object to the Object gallery. After an object is created, it can be edited using standard *ISB* commands.

**Note:**

An imported object can include sub-objects.

## Manipulating Objects

### Select objects

To manipulate an object you should select it in the Perspective View, in the Scene Tree, or in the Plan window.

**Note:**

Pictures and movies can be selected only in the Scene Tree window.

To select an object in the Perspective View window:

-  Click the object. The selected object is marked with a yellow bounding box.

To select an object in the Scene Tree window:

- Click the object's name. The name of the selected object is highlighted.

To select an object in the Plan window

- 1 Move the pointer into the Plan window and point to the edge of the object you want to select in the Plan window. The pointer should look like an arrow with a house near it.

- 2  Double-click one of the visible edges of an object. Both views are shown in red.

The selected object is displayed in the following manner:

-  In the Perspective View window the object is marked by a yellow bounding box.

- 

In the Scene Tree window the object's name is highlighted.

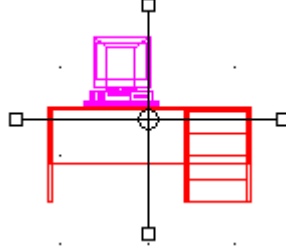
- 

In the Plan window the object's views are red. Its sub-objects appear in magenta.

**Note:**

When the whole scene is selected there is no yellow bounding box in the Perspective View window. All scene objects are indicated by the color magenta in the Plan window.

## Create objects

To create a new object which is a sub-object of the current object in the scene:

-  Choose New from the Object menu or click New Object on the Edit toolbar. The Object editing mode is entered. The Scene Tree window displays a new node with the name assigned by default.
- Construct an object using shapes. All operations described in the “Construct scene” chapter are valid for objects too.
- Choose Back to Scene from the Object menu or click Object Edit on the Edit toolbar to release it. The Save Object dialog box appears.
- In the Save Object dialog box, choose the desired saving mode:
  - Click Scene to place the object directly into the scene at the origin of its coordinates.
  - Click Clipboard to place a new object into the clipboard for later insertion into a scene.
  - Click Object Gallery to save a new object in the gallery. In the Name field, define the name which will accompany object in the Object gallery. In the field Category, define the name of the gallery category where the object is to be included.
  - Click Yes to save the object, click No to return to the Scene Assembling mode without saving the object, or click Cancel to return to the Object editing mode.

**Note:**

If you place a newly created object into the clipboard, you can later insert the object into any part of a scene, at any level of its hierarchical structure.

## Saving current object

To save the current object:

- Click Save on the Object menu. The dialog box appears.
- In the field Name, define the name under which the object will be displayed in the Object gallery.
- In the field Category, define the name of the category where the object is to be included.
- Click OK.

To save an object in the current Object Gallery:

- Drag the name of the object from the Scene Tree window to the Object gallery. The object is copied into the specified gallery.

**TIP:**

Object files in the gallery store information about the object's orientation, including the direction of the vertical axis of its coordinates. An object in the gallery is displayed so that its orientation coincides with that it will have when placed into a scene. While dragging an object to a face in the Perspective View window, the object "falls" such that its vertical axis coincides with the target face's normal. Therefore, an object such as a chair oriented in the gallery with its legs downward is always placed on a scene face with its legs on. If an object is turned on its side in the Object Editing mode and saved in the gallery, then subsequently added to a scene, it will also "lie" on its side on the scene face. Our advice is to keep track of the object orientation before saving it in the gallery, if the notions "top and "bottom make any sense (for example, objects like furniture).

## Deleting objects

To delete an object:

- 1 Select the object (see "Select objects" for details) to be deleted.
- 2 Choose Delete on the Edit menu or press Del key.

## Renaming objects

To rename an object:

- 1 Right-click the object name in the Scene Tree window. When the pop-up window appears choose Rename. You may also click the object name in the Scene Tree window. An edit box for the object name appears.
- 2 Enter the new name and press Enter.

## Get object info

To get information about an object:

- 1 Right-click the object in the Scene Tree window.
- 2 Choose Info in the pop-up menu. The window describing the object appears.

## Move and copy objects into another place in scene

To transfer an object to another scene place:

- 1 Click the object name in the Scene Tree.
- 2 Drag the object icon to any face of a scene in the Perspective View window. The object is placed as if the face is holding it up. For example, when an object such as a chair is dragged to the vertical face of a scene, the chair is placed with its legs directly in contact with this face, as if the face was the ground.

To copy an object to another scene place:

- 1 Click the object name in the Scene Tree window.
- 2 Drag the object icon to any face of a scene in the Perspective View window while holding down the Ctrl key. The object is copied as if the face is holding it up. For example, when an object such as a chair is dragged to the vertical face of a scene, the chair is placed with its legs directly in contact with this face, as if the face was the ground

**Notes:**

- An object cannot be moved or copied to a vacant space in a scene, to its own face, or to a face of

its sub-object by the above method.

- If an object is moved or copied to a face of another object, it becomes its sub-object and is placed on directly on the other's face.
- When an object is moved or copied, all its sub-objects are also moved or copied, retaining their orientation relative to the parent object.

## Move and copy objects into another hierarchy level

To move an object:

- Drag its name to the name of the object you want to make a parent - drag until the parent's name becomes highlighted in the Scene Tree window.

## Fitting windows to objects

To make object views visible in the Plan window:

-  Click Fit to Object on the Plan toolbar.

### Notes:

- If only one view is open when you choose the Fit to Object command, the scale of the plan is adjusted specifically to this window. The plan of the object may not fit into the window of the other view when it is opened.
- Objects on the plan have the dimensions of a rectangular parallelepiped, where the object and its sub-objects, together with cameras, are included. The scale of the plan is adjusted so that all components of the object are visible.
- This command is executed automatically when you enter the Object Editing mode.

## Editing Objects

### Edit objects

You can edit objects in the Scene Assembling and Object Editing modes.

It is convenient to edit an object in the Scene Assembling mode if you want to adjust its size or orientation relative to the other components in the scene. For example, you would use this mode to make two tables of the same height. You can also edit objects using shape operations. The edited object is not saved automatically in the Object gallery. You must save it by yourself using the procedure described in the "Saving current object" section.

### Note:

If an object is saved to the gallery after it is edited in the Scene Assembling mode, only the results of operations with shapes and painting/texturing are saved. The changes in size, proportion or object orientation which were made directly in the scene or while editing its parent object are not saved.

The Object Editing mode allows you to create a new object or completely modify the existing one. The object is automatically saved in the Object gallery or placed into the scene or clipboard. All modifications including rotation, scaling and skewing are saved.

## Changing size, position and orientation using Object Manipulator

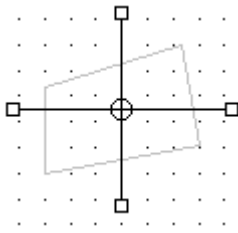

Object position, orientation, size and proportions are set with the Object Manipulator. It is turned on while selecting an object in the following way:

- 1 Position the pointer in the Plan window. If positioned on any line on the scene plan the form of the mouse pointer changes to an arrow with a house icon and displays the object name associated with this line.



- 2 Double-click a plan's line associated with the desired object. The object becomes selected and the Object Manipulator appears nearby.

To change an object's position:



- Drag the Object Manipulator's moving point (it's center). The moving point coordinates are seen on the status bar as the pointer is in motion. You can move an object in any of the three virtual space dimensions using the top view window for horizontal movements, and the front view window for moving vertically and along one of the horizontal axes.

To change an object's size:



- Drag the Object Manipulator's resize jack (the boxes at the end of the object axes or "levers"). Coordinates of the center of the Object Manipulator and object's size in the direction of change are displayed on the status bar.

To change an object's orientation:



- Drag the Object Manipulator's lever. To rotate the box in the horizontal plane, rotate in the top view. To rotate (incline) the box in the vertical plane, rotate in the front view.

To skew an object:

- Drag the Object Manipulator's moving point while holding down the Shift key. If the moving point is relocated while holding down the Shift button, skewing of the object occurs: its center shifts while the bottom face remains stationary. The face that was initially the lowest upon addition to a scene always remains stationary under deformations, irrespective of any object rotations.

To achieve smooth object rotation:

- Hold down the Ctrl key while dragging a lever.

To resize an object in all dimensions at once:

- Press Gray + key on the numeric key pad to enlarge the object or the Gray - key to shrink the object.

### Related topic:

Set shape position, size, and orientation.

## Changing object's height using the Ruler

Two Rulers can be displayed in the Ruler window:

- The gray Ruler corresponds to the current shape, included into the scene. Use the gray Ruler to change the shape's height.
- The red Ruler corresponds to the current scene object (previously added to the scene). Use the red Ruler to change the height of the current object.

The top lath (the gray box on the top end) of the red Ruler defines the position of the top face of the current object's bounding box. The bottom lath of the red Ruler defines the position of the bottom face of the current object's bounding box.

To move the Ruler's laths:



- Position the pointer over the lath. The pointer looks like an arrow and a house.
- Drag the lath up or down.

**Note:**

If the current object is the entire scene, the red Ruler corresponds to the upper and lower limits of a parallelepiped, which includes all scene parts and all objects. Height resizing operations, however, are unavailable when the entire scene is currently selected.

## Add and extract shapes

- 1 Select the object you want to edit.
- 2 Include a draft shape (see "Include ready shape into a scene") into the scene, set its position, size and orientation with respect to the shape or object it will affect.
- 3 Apply shape using the Add, Extract, Copy, Cut or Delete operations. They are described in detail in the Apply shapes to scene section.



**Notes:**

- During shape operations only the frozen part of the edited object is changed - all other objects (as well as the scene) do not change.
- To keep the shape you have included into the scene present on the scene plan after you have applied it to the scene, hold down the SHIFT key while clicking the Add, Extract, Cut or Copy commands. You can apply the same shape once more next time.

## Cut, copy, and paste objects and their parts

You can cut or copy an object or part of an object onto the clipboard and paste it into another place in your scene. You define an object part for cutting or copying using a shape.



To cut or copy the whole of the object onto the clipboard:

- 1 Select the object you want to edit.
- 2  Click the Cut button on the Standard toolbar or choose Cut on the Edit menu to cut the object to the clipboard.  Click the Copy button on the Standard toolbar or choose Copy from the Edit menu to copy the object to the clipboard. The object and all its sub-objects are copied onto the clipboard.

To cut or copy part of the object to the clipboard:

- 1 Select an object you want to edit.
- 2 Include a draft shape (see "Include ready shape into a scene") into the scene or create a shape on the fly. Set the shape's position, size and orientation so that it contains some part of the edited object.



-  Click Cut on the Standard toolbar or choose Cut on the Edit menu to cut part of the original object and parts of its sub-objects, inside the shape onto the clipboard.  Click Copy on the Standard toolbar or choose Copy on the Edit menu to copy part of the object and parts of its sub-objects, inside the shape onto the clipboard. To make Cut or Copy commands effective only to the current object, but not its sub-objects, hold down CTRL key while clicking the Cut or Copy buttons.

To paste data from the clipboard, do one of the following:

-  Click Paste on the Standard toolbar or choose Paste on the Edit menu to paste data from the clipboard to the scene's origin coordinates.
- Right-click the place in the Perspective View or Plan window where you want to paste data. The pop-up menu appears. Click Paste.

An object will be inserted into a scene so that the center of the parallelepiped which defines its limits will appear at the click point on the plan.

**Notes:**

- When you paste data from clipboard, the resulting object is always a sub-object of the currently selected object or scene. Be sure to select the desired parent object before doing the Paste operation.
- If you paste data that has been previously cut or copied from a scene into a scene, the result is a new independent object in the scene.

**TIPS:**

- To transform a part of a scene into an object, you may cut this part using the Cut or Copy operation and then insert it into a scene from the clipboard.
- To keep the shape you have included into the scene present on the scene plan after you have applied it to the scene, hold down the SHIFT key while clicking the Add, Extract, Cut or Copy commands. You can apply the same shape once more next time.

## Manipulating Objects in the Perspective View Window

### Manipulating objects in the Perspective View window

You can change the object's position, scale and orientation directly in the Perspective View window with the help of Object manipulator displayed in this window. This is useful when:

- You need to position and set the size of the object in 3D space relative to the other scene items and view the result directly in the Perspective View window.
- You need to place the object onto the specific face of the other scene item, for example on the ground landscape surface or on the floor of the virtual house.

To display the Object manipulator in the Perspective View window:

- Select the object you want to manipulate in the Perspective View window.
- Selected object is displayed with yellow frame parallelepiped around it, designating the object's bounding box position and orientation.
- Choose Manipulate Object command on the Object menu to display the Object manipulator controls on the bounding box frame edges and vertexes.

Using the Object manipulator controls in the Perspective View window you can:

- Rotate the object.
- Scale the object in all dimensions at once.
- Move the object to another place and snap it onto another face in the scene.

## Object manipulator controls in the Perspective View window

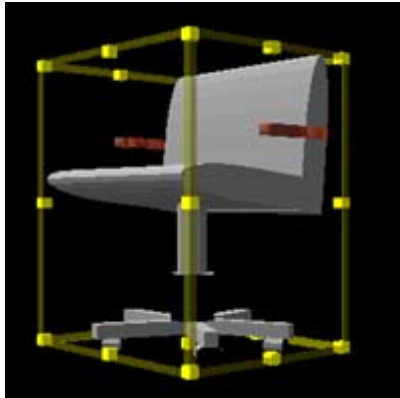

The Object manipulator controls in the Perspective View window are shown on the picture. There are three types of controls:

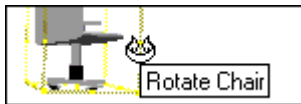

Object rotation controls: yellow boxes in the middle points of each edge of the object bounding box. When you position the mouse pointer over the rotation control a tool tip with the name of the operation and object's name appears on the screen.

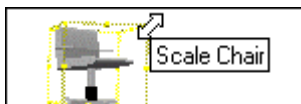

Object resizing (scale) controls: yellow boxes in each bound box vertex. When you position the mouse pointer over the scale control a tool tip with the name of the operation and object's name appears on the screen.



Object snapping/displacement control. This control is located in the middle of the bottom face of the object's bounding box. If the object is placed onto the face this control may be hidden. To make it visible you have to rotate the object around the axis, parallel to its bottom face first.

## Rotating the object directly in the Perspective View window

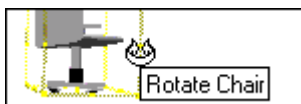

You can rotate the object in the Perspective View window using the rotation controls: yellow boxes in the middle points of each edge of the object bounding box. When you position the mouse pointer over the rotation control a tool tip with the name of the operation and object's name appears on the screen. Each rotation control rotates the object around the axis going through the center of object's bounding box parallel to the edge on which the rotation control is located. The procedure is illustrated by a set of pictures below:

- Rotating the object around the first chosen axis:

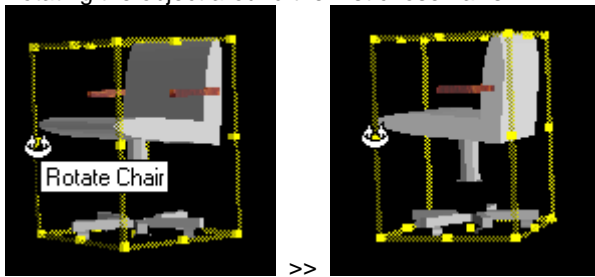

- Rotating around the next axis:

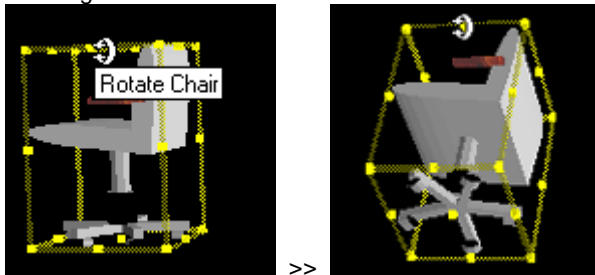

- Rotating around the last available axis:

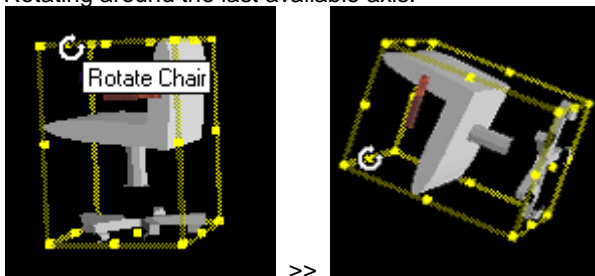

**Note:**

If you rotate the object around the axis, parallel to the bottom face of its bounding box, the object becomes not snapped to the face of the scene item. If you move it later it may turn back to snap to the face.

## Scaling the object directly in the Perspective View window

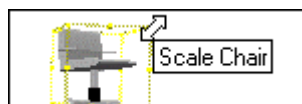

You can resize the object directly in the Perspective View window using the object scaling controls: yellow boxes in each bound box vertex. When you position the mouse pointer over the scale control a tool tip with the name of the operation and object's name appears on the screen.

Following rules are applied for the scaling operations:

- The object is resized (scaled) in all dimensions at once when you drag the scaling control:
  - increased, if you move the pointer out of the opposite diagonal vertex of the object bounding box
  - decreased, when you move the pointer closer to the opposite diagonal vertex of the object

bounding box.

- The opposite diagonal vertex of the object's bounding box always keeps its location in space while you are resizing the object. This ensures that the object does not expand into the wall or under the ground if you scale it by dragging the opposite to the wall vertex, as shown on the pictures below:

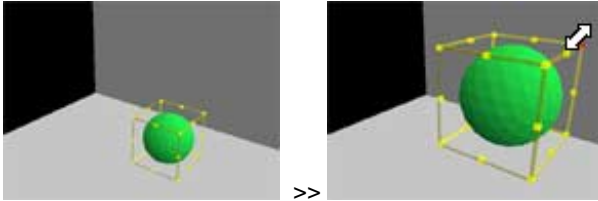

- If you scale the object while dragging its bottom vertex the object becomes intercepting the floor or the wall. Use this technique only if you actually need to insert the object into the other scene items.

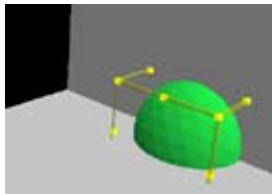

The result of scaling is illustrated on the picture below:

Try scaling the objects in the Perspective View window by yourself and find your own intuitive understanding of the scaling procedures.

## Moving the object directly in the Perspective View window



You can move the object and snap it to any visible face of the other item in the Perspective View window using the object snapping/displacement control. This control is located in the middle of the bottom face of the object's bounding box. If the object is placed onto the face this control may be hidden. To make it visible you have to rotate the object around the axis, parallel to its bottom face first.

The steps below, illustrated by pictures explain typical procedure of moving the object in the Perspective View window in the scene, already containing other items:

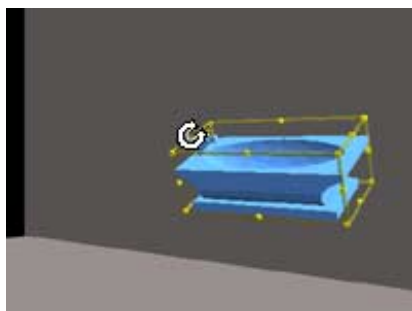

1. Select the object you want to move by clicking it in the Perspective View window. Click it once more or choose Manipulate command on the Object menu to show the Object manipulator in the Perspective view window. The object snapping control is hidden under the object and you have to rotate the object to make the snapping control accessible.

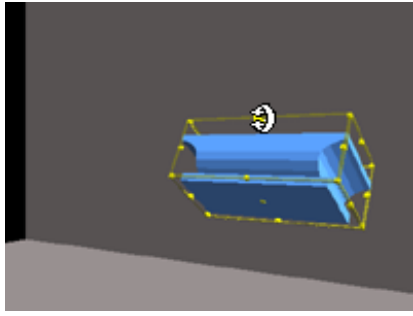

2. Rotate the object dragging its rotating control. Choose the proper rotation axis to make the bottom face of the object's bounding box clearly visible.

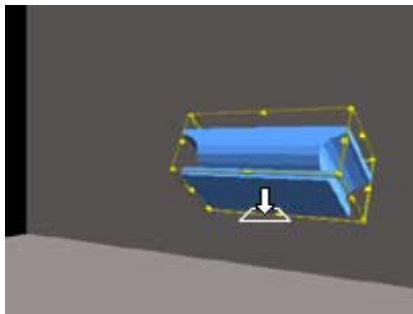

3. Position the pointer on the snapping control. A tool tip with the name of the operation and the object appears.

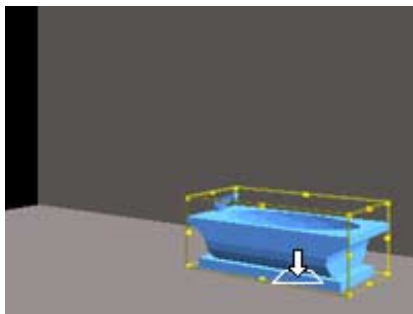

4. Move the pointer to make it pointing to the horizontal face in the scene. The object becomes attached by its bottom to that face and slides along it while you move the mouse. The snapping control is positioned on the face exactly in the point, defined by the mouse pointer position.

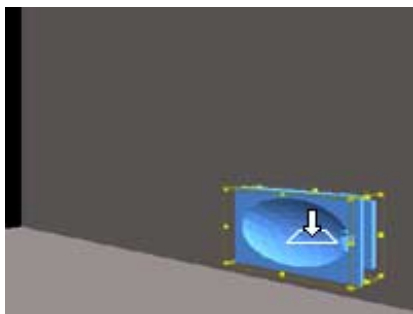

5. Move the pointer to make it pointing to the vertical face in the scene. The object becomes attached by its bottom to that face and slides along it while you move the mouse. The snapping control is positioned on the face exactly in the point, defined by the mouse pointer position.

You can also move the object inserted in to the empty scene with the help of the Object manipulator in the Perspective View window. The operation is explained and illustrated below. There may be two different cases: the object is placed into the empty space without visible faces or the object is not attached to any face, but there is another visible item in the Perspective View window. The pictures to the left and to the right from the text illustrate these cases.

- 1 Make the object snapping control accessible by setting the camera in appropriate position.

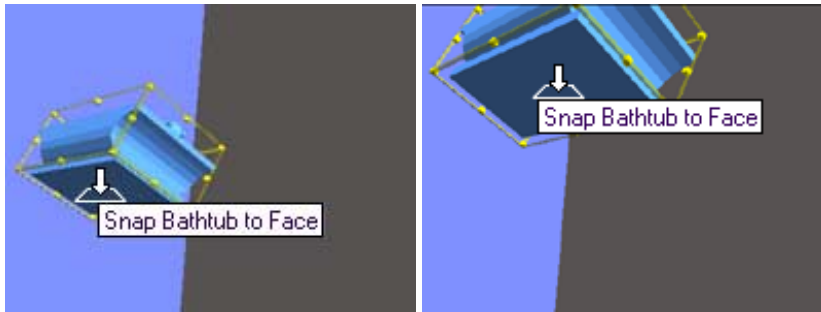

- 2 Now you can move the object by dragging its snapping/displacement control with the mouse in the Perspective View window. The object is moving along the plane to which belongs the bottom face of its bounding box. For the object orientation shown on the picture:

- Moving the mouse pointer up in the Perspective View window results in shifting the object up and closer to the camera.

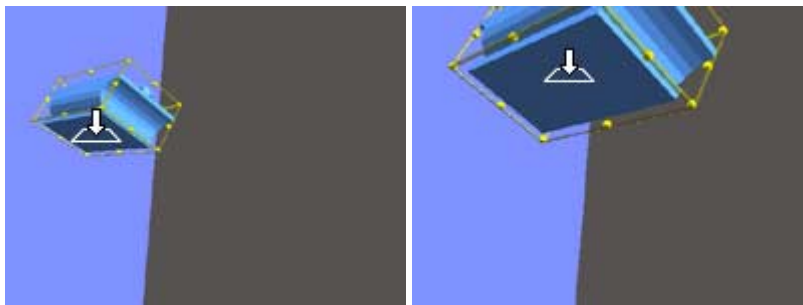

- Moving the pointer down in the Perspective View window results in shifting the object down and back from the camera.

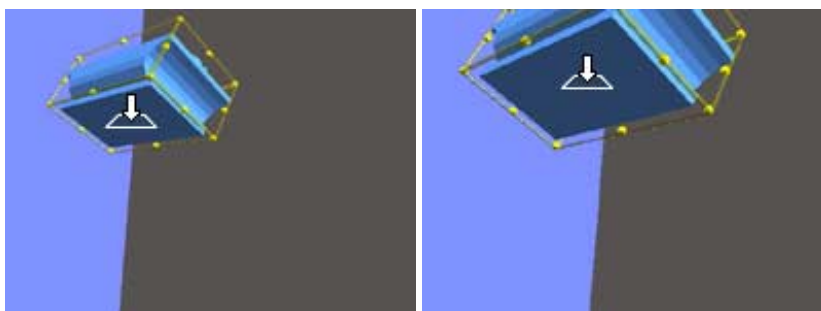

- Moving the pointer to the right results in shifting the object in the empty space along the horizontal (as it is displayed for the current object in the Perspective View window) edge of its bounding box or in snapping the object to the face of the item, located behind the object. Because the distance between the camera and the box behind the object is bigger than to the object, the object jumps in space to become attached to the face which you have pointed by the mouse.

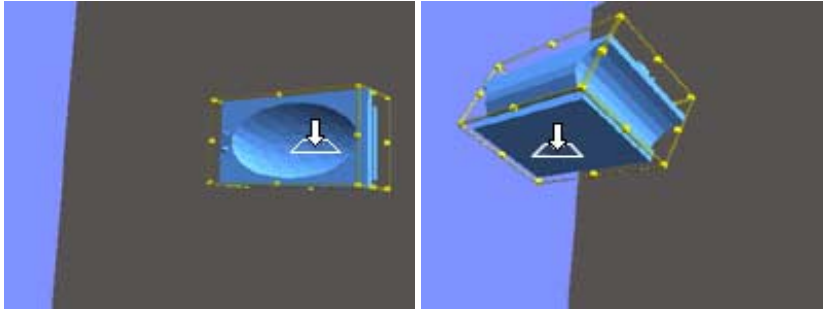

- If you continue moving the pointer to the right the object snaps to the other face of the box.

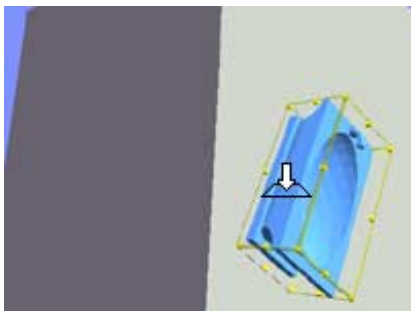

## Using VRML Geometry Primitives

### VRML primitives: overview

The three dimensional items in the scene are usually treated in *ISB* as sets of faces. For example, if you create an object by adding the shape Cone56 to the new empty object in the Object Editing mode (see "Editing objects in the Object Editing mode"), the object you have created is a set of 57 faces looking like a cone. While there is no difference for you what is actually written in the scene file, the size of the file, describing set of faces, simulating smooth sphere, cylinder or cone may be very large.

VRML 2.0 language includes a special geometry nodes, describing the primitive objects Box, Cone, Cylinder and Sphere which description in the file contains only the corresponding keyword and several numbers describing the primitive dimension. Using these primitives you can significantly reduce the size of scene file. The following rules are applied to the VRML primitive objects in *ISB*, reflecting the VRML language specifications:

- Because each VRML primitive object has only limited number of parameters there are some limitations on their re-sizing and rotating while you are editing them in the Object Editing mode. The corresponding limitations are described in the Help topics about each primitive. In the Object Editing mode the limitation are reflected by the absence of the Object Manipulator control, responsible for the prohibited action.
- Because the primitives are not face sets, *ISB* can not preserve the object description as a keyword with few parameters if you apply the shape to VRML primitive object, overlapping in space with it the while editing. The resulting object will be converted to a set of faces.
- If you apply shape (or several shapes), separated in space from the primitive, the scene file will contain an object description combined from an indexed faceset node and a short description of the primitive within the same object.
- You can not combine two VRML primitives within the same object in *ISB*. Each VRML primitive object is defined as a separate object. You can insert new VRML primitive object as sub-object of the scene or any other object, including another VRML primitive.
- All VRML primitive object's surface is treated in the VRML language specifications as a single face. There are special rules concerning the way the texture is mapped on that face, individual to each primitive object. That is why you can apply only single texture to the VRML primitive object as a whole. When you drag the texture onto the object in the Perspective View window all object surface is highlighted and the texture is placed on it following the VRML specifications. You can perform all mapping operations for the texture on the VRML primitive object in the same manner as for the ordinary object's faces in *ISB*. The difference is that in case of VRML primitive object, texture mapping is always applied to entire object's surface instead of a single face of ordinary (faceset) object.
- If an object is composed of a VRML primitive and a set of faces, separated spatially, then you can use the texture applying and mapping operation to a faceset part of such object in a normal for *ISB* manner.
- You can resize, rotate and skew VRML primitive object in all directions only if you are in the Scene assembling mode or while editing the VRML primitive parent object in the Object editing mode. That is because VRML primitive must remain correctly described by its parameters in its own coordinate system.

### Box VRML primitive object

You can create a new solid box (rectangular parallelepiped) as a VRML primitive object. The object created will become sub-object of the current object.

To create a new VRML primitive object Box:

- Choose New command on the Object menu, point to Box item on the drop-down sub-menu and click the left mouse button.

The box created with that command follows the VRML 2.0 specifications of the geometry node Box. The Box node specifies a box as a rectangular parallelepiped, located in the coordinate system's origin with



its faces oriented parallel to the coordinate system axes. In *ISB* VRML primitive objects are always created as objects and the above definition is valid in the object coordinate system, or, in other words, while you are editing the Box in the Object Editing mode (see “Editing objects in the Object Editing mode”). However you can move, rotate, resize and skew the Box primitive object freely in the Scene assembling mode or while editing its parent object.

While editing the Box in the Object Editing mode you can change only a Box width, depth and height with the Object Manipulator. You can not rotate or skew a Box. The Object Manipulator for the Box primitive does not allow rotating and skewing operations.



The Box surface is treated as a single face. So if you apply a texture to a box entire its surface is textured. The texture image is applied to the whole box face without tiling by default. The texture image is applied to the front face keeping texture coordinates parallel to the box edges. The other faces of a Box are textured in a way, keeping the texture image looking “naturally while you rotate the Box. On the picture to the left this is illustrated by a Box, textured with the image shown above the box, which you can read in normal direction while you rotate the Box.

**Note:**

While editing, if you apply a shape which intercepts with a box, the resultant object will be transformed to an indexed faceset. Indexed faceset description takes much more size into the scene file. You can not texture all faceset as a single face. Each time you attempt to apply a shape which cause the transformation of the base VRML primitive node to an indexed faceset you get a message box with a warning.

## Cylinder VRML primitive object

You can create a new solid Cylinder as a VRML primitive object. The object created will become sub-object of the current object.

To create a new VRML primitive object Cylinder:

- Choose New command on the Object menu, point to Cylinder item on the drop-down sub-menu and click the left mouse button.



The Cylinder created with that command follows the VRML 2.0 specifications of the geometry node Cylinder. The Cylinder node specifies a Cylinder, located in the coordinate system’s origin with its axis oriented parallel to the vertical coordinate system axis. In *ISB* VRML primitive objects are always created as objects and the above definition is valid in the object coordinate system, or, in other words, while you are editing the Cylinder in the Object Editing mode. However you can move, rotate, resize and skew the Cylinder primitive object freely in the Scene assembling mode or while editing its parent object. While editing the Cylinder in the Object Editing mode you can change only a Cylinder radius and height with the Object Manipulator. You can not make its bottom face elliptical, rotate or skew a Cylinder. The Object Manipulator for the Cylinder primitive does not allow rotating and skewing operations.

The Cylinder surface is treated as a single face. So if you apply a texture to a Cylinder entire its surface is textured. The texture image is applied to the Cylinder side surface without tiling by default. The texture image is applied keeping vertical texture coordinate parallel to the Cylinder axis. Top and bottom faces of a Cylinder are textured in a way, keeping the texture image looking “naturally while you rotate the Cylinder. On the picture to the left this is illustrated by a Cylinder textured with the image shown above the cylinder, which you can read in normal direction while you rotate the Cylinder in the scene.

**Note:**

While editing, if you apply a shape which intercepts with a Cylinder, the resultant object will be transformed to an indexed faceset. Indexed faceset description takes much more size into the scene file. You can not texture all faceset as a single face. Each time you attempt to apply a shape which cause the transformation of the VRML primitive object to an indexed faceset you get a message box with a warning.

## Cone VRML primitive object

You can create a new solid Cone as a VRML primitive object. The object created will become sub-object of the current object.

To create a new VRML primitive object Cone:

- Choose New command on the Object menu, point to Cone item on the drop-down sub-menu and click the left mouse button.

The Cone created with that command follows the VRML 2.0 specifications of the geometry node Cone. The Cone node specifies a cone, located in the coordinate system’s origin with its vertical axis parallel to the coordinate system vertical axis. In *ISB* VRML primitive objects are always created as objects and the above definition is valid in the object coordinate system, or, in other words, while you are editing the Cone in the Object Editing mode. However you can move, rotate, resize and skew the Cone primitive object freely in the Scene assembling mode or while editing its parent object.

While editing the Cone in the Object Editing mode you can change only a Cone bottom face radius and height with the Object Manipulator. You can not make its bottom face elliptical, rotate or skew a Cone. The Object Manipulator for the Cone primitive does not allow rotating and skewing operations.



The Cone surface is treated as a single face. So if you apply a texture to a Cone entire its surface is textured. The texture image is applied to the whole Cone side surface and its bottom face without tiling by default. When a texture is applied to the sides of the cone, the texture wraps counterclockwise (from above) starting at the back of the cone. The texture has a vertical seam at the back of the Cone. The other faces of a Cone are textured in a way, keeping the texture image looking “naturally while you rotate the Cone. On the picture to the left this is illustrated by a Cone textured with the image shown above the cone, which you can read in normal direction while you rotate the Cone.

**Note:**

While editing, if you apply a shape which intercepts with a Cone, the resultant object will be transformed to an indexed faceset. Indexed faceset description takes much more size into the scene file. You can not texture all faceset as a single face. Each time you attempt to apply a shape which cause the transformation of the VRML primitive object to an indexed faceset you get a message box with a warning.

## Sphere VRML primitive object

You can create a new solid Sphere as a VRML primitive object. The object created will become sub-object of the current object.

To create a new VRML primitive object Sphere:

- Choose New command on the Object menu, point to Sphere item on the drop-down sub-menu and click the left mouse button.

The Sphere created with that command follows the VRML 2.0 specifications of the geometry node Sphere. The Sphere node specifies a Sphere, located in the coordinate system's origin. In *ISB* VRML primitive objects are always created as objects and the above definition is valid in the object's local coordinate system, or, in other words, while you are editing the Sphere in the Object Editing mode. However you can move, rotate, resize and skew the Sphere primitive object freely in the Scene



assembling mode or while editing its parent object. While editing the Sphere in the Object Editing mode you can change only a Sphere radius with the Object Manipulator. You can not make it ellipsoidal, rotate or skew a Sphere. The Object Manipulator for the Sphere primitive does not allow rotating and skewing operations.

The Sphere surface is treated as a single face. So if you apply a texture to a Sphere entire its surface is textured. When a texture is applied to a sphere, the texture covers the entire surface, wrapping counterclockwise from the back of the sphere. The texture has a seam at the back of the Sphere. On the picture to the left this is illustrated by a Sphere textured with the image shown above the sphere.

**Note:** While editing, if you apply a shape which intercepts with a Sphere, the resultant object will be transformed to an indexed faceset. Indexed faceset description takes much more size into the scene file. You can not texture all faceset as a single face. Each time you attempt to apply a shape which cause the transformation of the VRML primitive object to an indexed faceset you get a message box with a warning.





## Using Plain Text Objects

### Using Plain Text objects

You can create Plain Text object as a sub-object of the current object. The plain text object created follows the VRML 2.0 specifications of the geometry node Text. VRML Text node defines text, displayed as a two sided face in the scene. Plain Text object is described in the scene file with the corresponding keyword and a text with several parameters. Compared with the 3D Text object, defined in *ISB* such description takes much less space. However because the Plain Text object does not have thickness, you can create only flat writings using this object. Following options are supported for the Plain Text object:

- You can edit the text writing, change its font, font style, text alignment, orientation, line and character spacing.
- Plain Text object is treated in the scene as a single face. So the texture is always applied to all characters in the Plain Text object.
- If you apply shape while editing the Plain Text object and it intercepts in space with the Plain Text the whole object will be converted to a set of faces. That is because *ISB* cannot preserve short Text description used in VRML language in this case.
- The width of Plain Text object is defined by the length of the longest text line in the text. You can only resize the Plain Text object in all dimensions at once. The proportion between its width and height is defined by the font, font style and character and line spacing parameters.

To create a new Plain Text object:

- 1 Choose New on the Object menu, point to Plain Text and click the left mouse button. *ISB* switches into the Object Editing mode. An example of Plain Text object containing Plain Text writing is shown in the Perspective View window. Plain Text object Format dialog box appears. In this dialog box you can edit a text string and set its font and alignment properties.
- 2  **Text.** Enter the text in this field. The text may contain several lines. Each line is located below the previous line for the horizontal text orientation or to the right from the previous line for vertical text orientation. To edit the text when the Format dialog box is closed click the arrow to the right from the Text button and edit the text in a small textbox which drops down.
- 3  **Font.** Select a font from the list of available fonts. To select font when the Format dialog is closed select font from the list on the Formatting toolbar
- 4  **Font style.** Select a font style from the list of available font styles. To select font style when the Format dialog is closed click Bold or Italic buttons on the Formatting toolbar.
- 5  **Alignment.** Select the alignment type from the list. To set text alignment when the Format dialog is closed click the corresponding button on the Formatting toolbar.
- 6  **Orientation.** Select the text lines orientation. Note, that the characters in the lines of the Plain Text object always have vertical orientation. Orientation button on the formatting toolbar performs the same action when the Format dialog box is closed.
- 7 **Line spacing.** Select the line spacing from the list. To set more than double line spacing set Multiple in the Line spacing field at set the desired number in the At field.
- 8 **Character spacing (scale).** Select the value of character spacing from the list. This setting does not affect the characters height.
- 9 **Default button.** Click this button to restore the default text formatting settings.

Click OK to apply changes, close the dialog box and view the result of formatting in the Perspective view and Plan windows or click Cancel to cancel formatting.

 Click Text button on the formatting toolbar or choose Format command on the Text menu to revert to editing of text in the Plain Text object and open the Format dialog box.

To edit already existing Plain Text object:

- 1 Select the object containing Plain text
- 2 Click the Object Plan tab below the Plan window to switch to the Object editing mode.
- 3 If the object you are editing contains VRML primitive Text as a part Formatting toolbar appears below the Standard toolbar of *ISB* screen.
- 4 Edit the Plain Text object using the Formatting toolbar or Format dialog box commands described above in this topic.

#### Notes:

- If you have already converted the Plain Text object to an indexed face set it becomes ordinary *ISB* object. Text formatting commands are no longer available for this object.
- If you have added the face set part to the Plain Text object, not intercepting with text in space you are still allowed to format the text. The face set part of such object is resized in all dimensions as well as Plain Text part while you are resizing the object in the Object editing mode.

## Using 3D Fonts

You can include an inscription with solid characters from any True Type font in a scene as an object. The 3D Text dialogue box is opened by the 3D Text command from the Object menu, which permits you, in addition to text editing, to choose a font, set character color and execution quality. The picture shows an example of using 3D fonts.

To enter 3D text:

- 1 Choose 3D Text from the Object menu. A dialog box appears.
- 2 In the Font list box, select the desired font.
- 3 In the Font style section choose the desired style.
- 4 In the Color list box, select the color for text.
- 5 In the Script field, choose a character set available for this font.
- 6 In the Geometry section, enter the values for character height and thickness. Choose the quality of the display in a scene.
- 7 In the Text field, enter the desired text.
- 8 In the Insert to box, choose Clipboard to place text object onto the clipboard, Object gallery to place it to the Object gallery, or Scene to place it into the scene.
- 9 Click OK.

**Notes:**

- You may preview the animated (rotating) text string in the bottom window of the Add Text dialog box. In the right bottom corner of the dialog box you can view the number of faces and vertexes of the 3D text object. Note that complex objects having a large number of faces occupy more disk space and memory. Consequently they may take longer to load.
- You can paste text from the clipboard into a scene using the Paste command.
- Text placed into the Object gallery becomes available for scene construction like any other object from the Object gallery.
- Text placed into a scene becomes a sub-object of the current object. It appears at the origin of the scene's coordinate system.

## Multimedia Capabilities

### Attach sound

You may attach sound to any scene object, including pictures and movies. You may attach sound from a file, you can record it from a microphone or from any audio source supported by your sound card.

To attach sound from a file:

- 1 Click the right mouse button on an object, a picture or movie in the Perspective View window, the icon of an object, a picture or movie in the Scene Tree window.
- 2 Choose Attach sound on the Object menu. The Edit Sound Attachment dialog box appears.
- 3 Click the Browse button to specify a sound file.
- 4 Specify the sound file and click OK.

To record sound:

- 1 Click the right mouse button on an object, a picture or movie in the Perspective View window, the icon of an object, a picture or movie in the Scene Tree window.
- 2 Choose Attach sound on the Object menu. The Edit Sound Attachment dialog box appears.
- 3 Click Record to start recording. The length of a record may not exceed 1 minute.
- 4 Click Stop when recording is finished.
- 5 Click Play to hear recording.
- 6 Repeat the writing and sound hearing operations if necessary. After the desired sound is recorded, press OK. The standard dialog box for file specification appears.
- 7 Name the sound file and click OK.

**Notes:**

- The internal sound recorder is working in 8 bit mono mode. Use the volume control program of

your operating system to set the recording levels for all sound sources, such as microphone, line in, midi, etc. For better sound quality prepare the sound file using specialized sound recording software.

- In addition to the above method, sound can be attached to the current scene object through the Attach sound command from the Object menu.

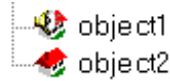

A scene element to which sound is attached is indicated in the Scene Tree window with a loudspeaker icon.

- You can also add sound by using the Attach MIDI from the File menu. This attaches a MIDI file to the current scene. It is played when the scene is loaded in the VRML browser.

## Play sound

To play sound:

- 1 Click the right mouse button on an object, a picture or movie in the Perspective View window, the icon of an object, a picture or movie in the Scene Tree window.
- 2 Choose Play sound on the Object menu. The sound attached to the object is played.

**Note:**

In addition to the above method, sound attached to the current scene object can be played through the Play sound command from the Object menu.

## Detach sound

To detach sound:

- 1 Click the right mouse button on an object, a picture or movie in the Perspective View window, the icon of an object, a picture or movie in the Scene Tree window.
- 2 Choose Detach sound on the Object menu. The sound attached to the object is detached.

**Notes:**

- In addition to the above method, sound attached to the current object can be detached through the Detach sound command from the Object menu.
- The detach sound command does not erase or remove the sound file from the computer disk.

## Link URLs

You can link a URL to any object, including pictures and movies.

To link URLs:

- 1 Click the right mouse button on an object, a picture or movie in the Perspective View window, the icon of an object, a picture or movie in the Scene Tree window.
- 2 Choose Link URL on the Object menu. The Link Internet Shortcut dialog box for URL specification appears.
- 3 Enter the full URL in the URL field.
- 4 Enter text in the Description field.
- 5 Click OK.

**Note:**

In addition to the above method, URL can be linked to the current object through the Link URL command from the Object menu.

## Removing URLs

To remove URLs:

- 1 Click the right mouse button on an object, a picture or movie in the Perspective View window, the icon of an object, a picture or movie in the Scene Tree window.
- 2 Choose Remove URL on the Object menu. The URL link is removed.

**Note:**

In addition to the above method, URL linked to the current object can be removed through the Remove URL command from the Object menu.

## Publishing Scene

### Preparing the scene for publishing

To prepare a scene for publishing *ISB* creates a new directory in which all data describing the scene is placed. This sub-directory will contain the scene's .wrl file and other resource files, for example, textures, sounds, pictures, etc. After the directory is created you may upload the scene to your Web site.

To prepare the scene for publishing:

- 1 Choose Publish on the File menu. The dialog box for the scene specification appears.
- 2 Enter the name of your scene .wrl file in the Scene name field.
- 3 Enter the full path name of a directory in the Location field. *ISB* creates a sub-directory with the name of the scene and places all required data there.
- 4 Mark the checkbox "Put all resources in one folder to have all scene files in one folder. Clear the checkbox to place resources independently, i.e. one sub-directory for the scene textures, another sub-directory for scene pictures, etc.
- 5 Click OK.

## Upload scene to the World Wide Web

To upload a scene to Web:

- Choose Post to Web from the File menu and then follow the instructions displayed on the screen.

**Notes:**

- Consult with your Internet Service Provider or Network administrator regarding how to set the correct data in the dialogs displayed on your screen.
- Install the Web Publishing Wizard software, distributed freely by Microsoft Corp. to use this feature of *ISB*.

## Texture Mapping

### Switching to the Texture Mapper window

To switch to the Texture Mapper window do one of the following:

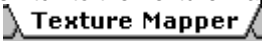
-  Click the Texture Mapper tab on the Switch bar.
- Texture Mapper Choose on the View menu.

## Placing textures into the Texture Mapper window

To place a texture in the Texture Mapper window for editing:

- Double-click a textured face in the Perspective View window. The texture is displayed in the Texture Mapper window. The face material becomes current material in the Material bar. The face with texture is highlighted by a yellow frame in the Perspective View window:

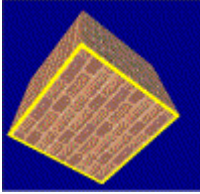

To replace a texture on a face and in the Texture Mapper window:

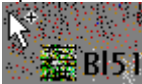
-  Drag a texture from the Texture gallery to the Texture Mapper window or to the Material Preview window at the top of the Material bar. The new texture is placed in the Texture Mapper window for editing. The face texture is also replaced in the Perspective View window.

## Moving textures

To move a texture:

-  Click and drag the texture in the Texture Mapper window in any direction. If you drag while the Shift key is pressed, texture movement is limited to the horizontal direction. If you drag while the Ctrl key is pressed, texture movement is limited to the vertical direction.

**See also:**

"Decorating scene" example in the *ISB's* Quick Start Guide document.

## Mapping the texture relative to a pivot point

To establish the pivot point:

-  Double-click any point of a texture in the Texture Mapper window - a push pin appears stuck into the texture at the click point.

To rotate a texture around the pin:

-  Drag the texture in the Texture Mapper window in any direction.

To stretch or shrink a texture relative to the point:

-  Drag the texture while the Shift key is pressed.

To rotate and stretch or shrink a texture simultaneously:

-  Drag the texture while the Ctrl key is pressed.



To rotate a texture 180 degrees:

-  Click Central Symmetry on the Texture toolbar.

To rotate a texture 90 degrees counter-clockwise



-  Click Rotate on the Texture toolbar.

**See also:**

"Decorating scene" example in the *ISB's* Quick Start Guide document.

## Mapping textures relative to a line

To establish the relative line:

- 1  Double-click any point of a texture in the Texture Mapper window - a push pin appears stuck into the texture at the click point.
- 2  Double-click any other point of the texture in the Texture Mapper window - one more pin appears, with a line connecting the two pins. Position the pins by dragging them on the texture to establish mapping directionality.

To stretch or shrink a texture relative to the line:

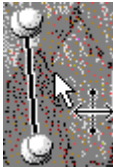

- Drag the texture in the Texture Mapper window in any direction - the texture is stretched/shrunk relative to the line.

To displace a texture relative to the line:



- Drag the texture while the Shift key is pressed - the texture is displaced relative to the line.

To displace and stretch or shrink a texture relative to the line:

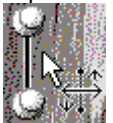

- Drag the texture while the Ctrl key is pressed - the texture is simultaneously displaced and stretched or shrunk.

To mirror a texture relative to the line:

-  Click Mirror on the Texture toolbar.

To make a horizontal texture axis parallel to the relative line:

-  Click the Align Horizontal button on the Texture toolbar. We define vertical and horizontal directions on the screen as texture coordinate axes when a texture is displayed without transformations.

To make a vertical texture axis parallel to the relative line:

-  Click the Align Vertical button on the Texture toolbar. We define vertical and horizontal directions on the screen as texture coordinate axes when a texture is displayed without transformations.

**See also:**

"Decorating scene" example in the *ISB's Quick Start Guide* document.

## Restoring the initial texture

To return a texture to default state:

-  Click Default on the Texture toolbar - the texture reverts to its original state.

## Changing texture transparency

You can set the material transparency in the Material bar with the Transparency control slider.

To set the material transparency:

- Drag the Transparency control slider on the Material bar up to increase the material transparency value.
- To revert to the opaque material:
-  Click the Opaque button.

**See also:**

"Decorating scene" example in the *ISB's Quick Start Guide* document.

## Removing textures

You may remove a texture from a face to restore its initial color. You may also change the initial color.

To change the base color of the face under the texture, open the Material bar by Double-clicking the Material Preview window:

- Click anywhere in the Color Circle, and then use the Luminosity slider below to adjust the color's attributes.
- If you define a color using the Red/Green/Blue scales, you can look at this circle to make sure you defined the color as you intended.
- To paint a face with the desired color, delete the current texture by clicking the Clear button on the toolbar at the top of the Material bar.

To remove a texture from a face:

-  Click Clear - the texture is removed. The face returns to its original, non-textured base color.

**See also:**

"Decorating scene" example in the *ISB's Quick Start Guide* document.

## Animating textures

To create animated (moving) textures:

-  Drag the green circle from the center red arm from the center of the texture animation

control on the Material bar to set the direction and the speed of the texture's movement. A longer arm results in faster motion. To stop the motion:



-  Click the Stop button on the Material bar.

**See also:**



"Decorating scene" example in the *ISB's* Quick Start Guide document.

## Copy modified textures to faces

To spread a face material properties, including the modified from one face to the others:

1.  Click the Spread button on the Brush toolbar.
2.  Position the pointer over the face with the required material properties in the Perspective View window. The pointer looks like a brush.
3. Hold the left mouse button.
4. Drag the material through all faces to be applied.

To spread a texture or color over the whole object:

1.  Click Spread on the Brush toolbar.
2.  Position the pointer over the face with the required texture or color in the Perspective View window. The pointer looks like a brush.
3. Double-click the face - all other faces of the object are textured or colored.

**Notes:**

- Transfer of material from a face of one object to the faces of other objects is impossible.
- Material transfer across parts, from one face to another, is impossible if there is any empty space, even if the two parts belong to the same object (scene).
- Using the Fill and Spread operation, a face material can be spread without skipping over the blank space or volume the part itself occupies. If there is a closed cavity inside a figure (the inner part of it is cut out), its external and internal faces are filled by material independently.
- By Double-clicking a face, a face material is applied to all the faces of the frozen part of the scene or current object. All other objects including its sub-objects are not changed. For example, if there are two separate objects in a scene, the material will only be applied to the faces of the double-clicked object.
- If two isolated parts in a scene (object) are visually interconnected with a part belonging to another object, they are not considered interconnected in the sense of face material transfers.

**See also:**

"Decorating scene" example in the *ISB's* Quick Start Guide document.

## Texture Painting

### Switching to the Painter window

The Painter window allows for pen and mouse-based drawing on textures and pictures.

To switch to the Painter window:



- Choose Painter from the View menu. The Plan (or Texture Mapper) window in the right part of the *ISB* screen will be replaced with the Painter window. The Painter toolbar is located in the upper part of the Painter window. It has buttons to create and save pictures and textures. The Paint toolbar has sections to choose drawing tools, painting color and its attributes. This toolbar is in the right part of the Painter window.

**See also:**

"Editing textures and pictures" example in the *ISB's* Quick Start Guide document.



## Creating a new picture or texture

Textures and Pictures are created while in the Painter window:

- 1 Choose Painter from the View menu to display the Painter window.
- 2  Click the New picture or New texture button on the Painter toolbar . The window presents an empty canvas, upon which you will create or edit your picture or texture. The painter mode allows you to write and draw on a picture or texture, to paint their parts with different colors and to make transformations of selected parts.

## Placing pre-existing textures or pictures into the Painter window

To place a texture or picture in the Painter window for editing make one of the following:

- 1   **Anna** Display the Painter window. Drag the texture or picture from the corresponding gallery into the Painter window. The pointer looks like an arrow with a picture.
- 2 In the Perspective View window, right-click a face with a texture or on a picture you want to change. Choose Edit texture or Edit from the pop-up menu.
- 3 Double-click a picture in the Perspective View window, or on a texture in the gallery to edit it in the Painter.

**See also:**

"Editing textures and pictures" example in the *ISB's* Quick Start Guide document.

## Draw a straight line or rectangle

- 1 Click Line on the Paint toolbar to draw a line or click Rectangle to draw a rectangle.
- 2 Click a line width on the Width and Shape box to select a drawing width.
- 3 Click a color on the color toolbar to select a drawing color.
- 4 Drag the handle of the Transparency slider to define the color transparency.
- 5 Drag the handle of the Blur slider to define the color intensity.
- 6 Drag the mouse while holding down the mouse left button to draw a line or rectangle.

## Draw a free-form line

- 1 Click Pencil, Stylus or Brush on the Paint toolbar to select a drawing tool.
- 2 Click Weight on the Width and Shape box to select thickness of the drawing tool.
- 3 Click Color on the color toolbar to select a color.
- 4 Drag the handle of the Transparency slider to define the color transparency.
- 5 Drag the handle of the Blur slider to define the color intensity.
- 6 Drag the mouse pointer to draw.

## Fill an area with a color

You may fill an area of connected points whose colors are about the same. To fill an area:

- 1 Click the Fill button on the Paint toolbar.
- 2 Click a color on the color toolbar to select a color.
- 3 Drag the handle of the Transparency slider to define the color transparency.
- 4 Drag the handle of the Tolerance slider to define the tolerance, or allowable difference between points of color to be replaced in the selected area.
- 4 Click anywhere in the area to be painted. The area is filled.

## Using transparent colors

You can specify any color as transparent color while editing picture or texture. The information about transparent color will be stored in the image file and used by the browser while viewing the scene.

To set current drawing color as transparent color:

- Choose Transparent Color on the Paint menu, and then click the Set item. Current drawing color will be set as transparent in the image file.

To retrieve the color, specified as transparent color in the image file and make it current color:

- Choose Transparent Color on the Paint menu, and then click the Retrieve item.

To remove the transparent color information from the image file:

- Choose Transparent Color on the Paint menu, point on the Set command and click left mouse button. Transparent color assignment will be removed.

**Note:**

- Transparent Color options are available only for GIF and PNG image file formats.

## Manipulating selected areas

To select an area of the picture or texture:

- 1 Click Select on the Paint toolbar.
- 2 Draw a selection rectangle by left clicking and dragging with your mouse.

To move or copy the selected part over the picture or texture:

- 1 Click the movement mode in the Width and Shape control (movement mode is represented by two icons, both sunset drawings differentiated by how the sun looks in a selection rectangle). To move or copy a selected rectangle as a whole click the upper icon. To move or copy only those points of the area whose colors are different than the current color selected in the Colors toolbar, click the bottom icon.
- 2 Drag the selection area to move and place it.

To copy the selected area to the clipboard:

- Click Copy on the Standard toolbar or choose Copy on the Edit menu.

To clear the selected area:

- Choose Delete on the Edit menu.

To cut the selected area to the clipboard:

- Click Cut on the Standard toolbar or choose Cut on the Edit menu.

## Pick up a point color

You may pick a color to paint with from any point on the picture or texture. To pick a color:

- 1 Click Select Color (eyedropper) on the Paint toolbar.
- 2 Click the desired color on the existing picture or texture. That color becomes the current color and is placed on the current color box of the Painter toolbar.

## Zoom In a picture or texture

To magnify an area of a picture or texture:

- 1 Click Zoom on the Paint toolbar.
- 2 Click anywhere in the area to be magnified.

To change the picture or texture magnification:

- 1 Click Zoom on the Paint toolbar again.
- 2 Click the appropriate magnification value in the Width and Shape box to zoom in or out from the original view.

To return the picture or texture to its original size:

- 1 Click Zoom on the Paint toolbar.
- 2 Click anywhere in the picture or texture again.

## On-line picture or texture editing

You may edit a picture or texture already placed into a scene. When you edit on-line all changes are immediately displayed in the Perspective View window.

To make edit a picture or texture on-line:

- 1 Display the Painter window.
- 2 Double-click the desired texture or picture in the Perspective View window. The picture or texture is placed on the canvas in the Painter window. Its name and category is displayed in the Painter window toolbar.
- 3 Edit the picture or texture. All editing is displayed in the Perspective View window.

## Resizing a picture or texture



- Drag the black box on the edge of the picture or texture. With an increase of the image canvas the number of pixels increases. The picture or texture shown in the window is unchanged, and the additional canvas space is initially painted white. With a decrease in the size of the image canvas, the picture or texture is cropped along the new borders of the canvas.

## Saving a picture or texture

You can save a picture or texture in any of BMP, GIF, JPG or PNG image file formats supported in *ISB*.

To set the image file format for saving a picture or texture:

- Choose Format command on the Paint menu, then point to one of file formats in the drop-down sub-menu and click the left mouse button.

To save a picture or texture to a gallery:

- 1 To rename a picture or texture enter the new name in the Name field of the Painter window toolbar.
- 2 To define another category enter the new name in the Category field of the Painter window toolbar.
- 3  Click Save on the Painter window toolbar. The edited picture or texture is saved.

Instead of saving a picture or texture in a gallery you may save them to any folder and file location available to your system.

To save a picture or texture to the file:

- 1 Choose Save as from the Paint menu. The dialog box for file specification appears.
- 2 Click a drive name or folder name.
- 3 In the File Name box, type a name for the picture or texture.
- 4 In the Save as type field, choose a graphic file format.
- 5 Click Save.

**Note:**

*ISB* stores the texture galleries in the *ISB\Textures* directory by default.

## Controlling Gallery Resources

### Moving, adding and deleting gallery resources

You can move, add or delete resources in each gallery.

To move, add or delete gallery resources:

- 1 Right-click anywhere in the gallery. The pop-up window appears.
- 2 Click the Explore menu item. The standard Windows Explorer window with the gallery's file names appears.
- 3 Add or delete files using the Windows Explorer. All modifications are immediately displayed in the appropriate gallery.

## Working with the Scene Resources and Resource References

To open the Resources dialog box, choose Info command on the File menu and then click the Resources tab. This dialog box allows you to view and modify the references to resource files in the Scene:

- **Resources list box.** In this box you can view the list of all resource files, used in the Scene. You can set the sorting order by file Name, Type, Size, use Count and by Folder name. To set the desired sorting order, click the corresponding tab header. The number of selected resource files and their size are displayed on the bar at the bottom of the list box. If there is no files selected, total number of resource files used in the Scene and their size are shown instead. The files, which are referenced in the Scene file, but not available or corrupted format are shown with red cross over the file icon.
- **View use button.** Press this button to show the place in the Scene where the corresponding resource is used. The camera smoothly moves to the face with a texture, picture, movie or sound automatically. If the resource file is used on several faces of the Scene items, then the first face is displayed. You can switch to the other face with the help of the slider control to the right of View

Use button.

- **Slider control.** Use this control to view the specific face with resource, applied to many faces. The left position of the Slider corresponds to the current camera position in the Scene. When you move the slider to the right, a camera moves to show the face, which uses the selected resource file with increasing reference count. For example, if a textured cube is present in the Scene, than the texture file is used 6 times. When you click View use button the first counted by usage face of the cube is shown in the Perspective view window. If you move the Slider control to the right the faces, using the same texture with increasing usage count are displayed.
- **Preview window.** You can preview the image of texture, picture or movie frame in this window. For a sound (both WAV and MIDI formats) file a Play button substitutes the preview image. Click this button to play the sound. For an Internet shortcut the preview image is replaced by the button with the icon of your operating system default Internet browser program. Press this button to follow the link.
- **Rename button.** Press this button to rename the selected resource file.
- **Change button.** Press this button to open a dialog for replacement of selected resource file by another. The replacement takes place on all faces, using this resource file.

To apply changes, made in resource files references click the OK button.

To cancel all changes, made in resource files references click the Cancel button.

## Working with the resources, used in the Scene

While editing the scene you can get the information about the resources, used in it and modify them. This is useful if you need to check the space occupied by resources, find the place in the scene where the particular resource is used, resolve the problems with the resource, referenced in the file, but not found in the location specified in the scene. You can do these operations with the help of Resources dialog box.

To open the Resources dialog box:

- Choose Info command on the File menu and then click the Resources tab.

The Resources dialog box appears, which contains the list of all image and sound files, referenced in the scene along with the Internet shortcuts, attached to the scene objects and pictures. You can sort the resources by name, size, type, reference count, folder name in ascending or descending order.

 The resources references for which the corresponding files are not found are shown in the list by the icon with the red cross .

To set the resources sorting criteria:

- Click the corresponding header tab.

To invert the resources sorting order keeping the same sorting criteria:

- Click the same header tab once more.

Below the list of resources there is a status bar, showing either the total number and size of resources in the scene or the number and size of the selected resources.

To select a resource:

- Click its name in the resources list.

To select a group of resources:

- Click each resource name, holding down the CTRL key on the keyboard. All resources you have clicked will be selected. Or
- Click the first resource name, hold down the Shift key and click the last resource name in the list. All resources, located between the first and the last names in the list will be selected.



You can perform the following operations with the selected resources:

- View the use of single selected resource
- Rename the resources and change the image files format.
- Change the resource reference to another file of the same type

## Viewing where the selected resource is used in the scene

In the Resources dialog box you can view the scene item, using the selected resource. For this:

- 1 Choose Info on the File menu and then click the Resources tab. The Resources dialog box appears.
- 2 Select the resource by clicking its name in the resources list. Scroll the list using the vertical and horizontal scroll bars to make the resource file name visible.
- 3 The preview image of the selected resource (or the last selected resource in the group) is shown in the small preview window in the bottom right corner of the Resources dialog box. For sound files and Internet shortcuts the button, launching the system default program, associated with the file type is shown instead of the image. Click the button to check the Internet link or play the sound.
- 4  Click the View Use button. The camera moves to the position, suitable for viewing the face with the selected resource.
- 5 Click the View Use button once more. The camera moves to the next face, using the same resource. The reference count to the resource in the scene file is displayed by position of the slider located to the right of the View Use button and is written below it. The first number shows the reference number, the second number - total number of references to the current resource in the scene file. You can move the slider to set the reference number to the resource you want to view. The camera moves to the face, having the specified reference number to the resource in the scene file.

Using the View Use button you can find a specific place in the scene, containing the picture, texture, movie, sound or Internet shortcut. This is helpful, for example, when you have lost the resource file and need to find where it is referenced in the scene. Then you can change the resource file reference to another one or rename the existing resource file and copy it to the specified folder. While renaming the image file you can also convert it to one of available image file formats: BMP, GIF, JPEG or PNG.

Related topics:



- Working with the resources, used in the Scene
- Renaming resources
- Changing the resource reference in the Scene file

## Renaming resources

While editing the scene you can change the file name and location of resource, referenced in the scene. The resource file under the specified new name is automatically copied into the folder you have specified. This is useful if, for example, you decide to give new names to the files used in the scene and to edit them later keeping the original files unchanged.

To rename the resource file, used in the scene:

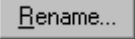
1. Choose Info on the File menu and then click the Resources tab. The Resources dialog box appears.
2. Select the resource by clicking its name in the resources list. Scroll the list using the vertical and horizontal scroll bars to make the resource file name visible. To select a group of resources click each resource name, holding down the CTRL key on the keyboard. All resources you have clicked will be selected. Or click the first resource name, hold down the Shift key and click the last resource name in the list. All resources, located between the first and the last names in the list will be selected.

3.  Click the Rename button. Rename Resources dialog box appears. In this dialog box you can change the name of the resource file, change its location and perform format conversion for the images, used as pictures, movies or textures.
4. **Change Location.** Place mark in this checkbox and enter a new path to the file in the field below. The file with the resource will be copied to the location you have specified and the scene will reference to the file at this location. To open standard Windows Choose Folder dialog press  the Browse button.
5. **Change Name.** Place mark in this checkbox and enter new file name in the field below. Do not enter the extension in this field - the file extension will be set according to the resource file format automatically.
6. **Change Format.** Place mark in this checkbox and select the image file format from the list of available formats. This option is available for image files only. You can not change the format of sound file or Internet shortcut. After you have changed the resource format a new file with the specified format and filename extension is created in the folder, specified in the Change Location field above. The scene file will contain the reference to this new file. The original resource file is not deleted.
7. Click the OK button. The Copying Resources dialog box with the information about the process of copying files is displayed.
8. The resource file or group of files will be converted to the new format (if specified) and copied to the folder, specified in the Change Location field under the name, specified in the Change Name field. The filename extension will be automatically set to the default extension for file format specified.
9. You can interrupt copying by clicking the Abort button.
10. After the copying is complete click OK to close the Copying Resources dialog box. The Rename Resources dialog will be closed too and you will return to the Resources dialog box.

To make the changes permanent and close Resources dialog box:

- Click the OK button in the Resources dialog box.

To cancel renaming of resources you have made while the Resources dialog box has been opened:

- Click the Cancel button. All references to the resources in the scene file will be reset to the state, which was before you have opened the Resources dialog. New files you have created while renaming the resources will not be deleted.

**Notes:**

- You can not change the file format for the sound files.
- You can not rename the Internet shortcut.
- You can not change the name for the group of selected files in the Rename Resources dialog box.
- While converting the group of files to the other format only image files are converted, the other files are ignored.
- A movie in *ISB* is a set of files, each file in a set is treated as a movie frame. To rename a movie you have to rename all movie frame files.

Related topics:

- Viewing where the resource is used in the Scene
- Working with the resources, used in the Scene
- Changing the resource reference in the Scene file

## Changing resource reference in the scene file

You can change the resource reference in the scene file to point it to another file, located in any folder. This is useful if, for example you decide to change the particular texture on all faces of multiple objects in the scene at once or you need to substitute missing resource file by another one.

To make the resource reference in the scene pointing to another file:

- 1 Choose Info on the File menu and then click the Resources tab. The Resources dialog box appears.
- 2 Select the resource the reference to which you decide to change.
- 3  Click the Change button. Change Resources dialog box appears. This is Change resource dialog box. In this dialog box you can replace the reference to the selected resource file in the scene.
- 4 **From** area. In this area the Name, Path, Type and Size and preview image of the resource file to be replaced are displayed.
- 5 **To** area. Enter the name and path to a new resource file in the corresponding fields. To find a file click Browse button. Preview image of the resource and its file size are also displayed in this area.
- 6 To remove the resource from scene place mark on the Nothing checkbox. All references to this resource will be removed from the scene file.
- 7 To apply changes to the scene resource file reference click OK.
- 8 To cancel changes click Cancel.

Related topics:

- Viewing where the resource is used in the Scene
- Working with the resources, used in the Scene
- Renaming resources

## Controlling the navigation type

The Scene Info dialog at the Navigation tab allows you to control the navigation type which is used in all major VRML browsers. Choose Info on the File menu and then click the Navigation tab. The corresponding dialog box appears.

- **Allowed navigation types.** Mark the check box to use the browser's navigation type. The browser's navigation user interface will be restricted to navigation types specified in the list. NONE navigation disables and removes all browser-specific navigation user interface forcing the user to navigate only mechanisms provided in the scene such as Anchor nodes or scripts.
- **Set as Default Type.** Press this button to apply Allowed navigation types by default for all scenes you will create.
- **Avatar size.** In this section you can set the physical dimensions of the avatar (the abstract representation of the user in a VRML world) for the purpose of collision detection and terrain following. Camera is used to view a scene; the position of the camera is considered to be close to the avatar's eyes. The Collision distance parameter specifies the minimal distance between the camera's position and an any collision geometry in a VRML world. Height above the terrain - the height above the horizontal surface at which the browser should maintain the camera. Height of the footstep - the height of the tallest object over which the viewer can move. All parameters are in meters.
- **Viewer settings.** The Headlight specifies whether a browser should turn on a headlight. The speed parameter determines the speed with which you move in meters per second.

You have changed this scene since the last time you saved it to disk. Before *ISB* closes it, you have a chance to update the disk copy.

**Yes** Click this button to save the scene to disk. If the file hasn't yet got a name, you'll see a dialog asking you to specify the file to save to.

**No** Click this button to irretrievably discard the changes you've made since the last save.

**Cancel** Click this button to abandon the operation completely and return to editing the scene.

## Setting ISB options

Choose Options... on the Tools menu and then click the corresponding tab.

### General

This dialog box allows you to define the general parameters of the scene.

- **Use compression for.** Mark the checkbox near the corresponding item to save new scenes, objects and previously published scenes in compressed format.
- **Undo buffer size.** Specify a limit for the number of Undo operations.
- **Play background MIDI.** Mark the checkbox to play a MIDI file attached to a scene. Clear the checkbox if you don't want the file to play.
- **Auto Repeat.** Mark the checkbox to repeat MIDI after it is finished. Clear the checkbox if you want to play MIDI once.
- **User info.** Specify the user and company names in the corresponding fields. These names will be documented in the scene's VRML 2.0 file.
-  Click this button to open the HTML Options dialog box. You may edit the HTML file to be uploaded to your Web page in this dialog box. A default HTML text file is already loaded, however you may modify the text manually prior to posting the scene.

### The HTML options dialog box

Here you can edit the HTML file to be created with Post to Web command. A default document is displayed in the editing box. You can edit HTML format text manually or insert the HTML language keywords automatically.

To edit HTML document manually:

- Click anywhere on the editing box and enter a text.

To insert HTML keywords:

- Position a cursor in the place, where you want to insert a keyword into the document. Click Insert button and then click a keyword on the popup list of available keywords. A keyword will be inserted to the right from the cursor's position. Refer to the HTML language syntax description before you begin editing a document.

To cancel all editing operations and restore the original document:

- Click Reset button.

To finish editing and close the HTML options dialog:

- Click Ok

To cancel current editing of document:

- Click Cancel.

### Plan

This dialog box allows you to specify a grid for the Plan window and to set the thickness of the walls for polygonal shapes.

- **Grid.** Mark the checkbox to turn the Grid on, or clear the checkbox to turn the Grid off.
- **Spacing.** Specify the Grid cell in meters.
- **Snap.** Specify the grid snapping proportion: select 1:1 in the Snap box to specify snap to grid cell, select 1:2 to specify snap to 1/2 cell, etc. Select None to turn the grid snapping off.
- **Guides.** Mark the checkbox to turn on the Guide lines in the Plan window. Enter the Top Guide and Bottom Guide heights in meters in the Top and bottom fields.
- **Thickness.** Specify the thickness of the wall, floor and ceiling for the Room and Wall polygonal shapes.
- **Spline.** Specify the default spline parameters.

## Camera

This dialog box allows you to control scene appearance and navigation in the Perspective View window.

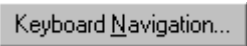
- **Rendering engine.** Select a rendering mode. The 256 Color/High Color/True Color Software 3D Render Engine options are preferable if your display works in the corresponding color mode. The Render Engines with MMX in their name are available only for the computers with processors supporting Intel's MMX instruction set.
- **Default picture resolution.** The number of pixels of picture image per 1 meter of the virtual space. To make a picture larger when it is on screen, decrease the number in the Horizontal and/or Vertical field.
-  Click this button to open the Keyboard Navigation dialog box. In this dialog box you can re-assign the keys for the keyboard navigation commands.

## Galleries

This dialog box allows you to control the *ISB* resources.

- **Category.** Select the name of the gallery.
- **Path to the resources.** Enter the name of the folder with the gallery resources or click the Browse button to search for the gallery folder.
- **Include subfolders.** Mark the check box to use resources from the subfolders of the folder specified in the Path to the resources edit box. If the checkbox is marked, the subfolders are shown in the corresponding gallery with a tab. The name of the tab coincides with the name of the subfolder.
- **Preview size.** Specify the size of the screen area for the resource preview. The size is specified in pixels.
- **Sort by.** Define the sort order for the resources. They can be sorted in ascending order by name, or in ascending or descending order by creation date.
- **Show ToolTips.** Mark the checkbox to display tool tips for gallery resources.
- **Enable animation.** Mark the checkbox if you want a resource to rotate when you point to it.
- **Allow fast load.** Mark the checkbox to save a resource preview image after the resource is loaded. This option is intended for complex resources such as scenes or objects. These resources are displayed much faster when their preview images are stored on the disk. If you modify a resource its image is automatically updated.
- **Show titles.** Mark the checkbox to display names of gallery resources.

## Texture Mapper

This dialog box allows you to define texture tiling parameters.

**Default scene texture tiling.** The number of meters of virtual space per one tiling unit. These parameters are used when you drag and drop a texture from the Texture gallery to a non-textured face in the scene.

## Keyboard Navigation dialog box

To open the Keyboard Navigation dialog box:

- Choose Options on the Tools menu, then click the Camera tab and click the Keyboard Navigation button.

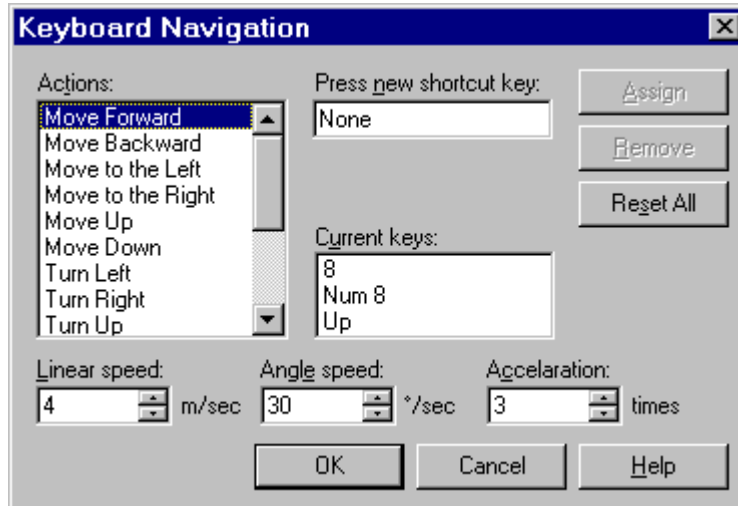

In this box you can re-assign the keys for the keyboard navigation commands and set the navigation properties:

- **Actions.** Select the navigation command in this list by clicking its name.
- **Press new shortcut key.** Click this field and then press on the keyboard a new shortcut key for the selected command. The key name you have pressed is displayed in this field.
- **Currently assigned to.** The navigation command name associated with the key you have pressed is displayed below this phrase. If the key is free from any previous assignment it is displayed as unassigned.
- **Current keys.** A list of the keyboard keys, associated with the selected camera navigation command is shown below this line. There may be any number of keys assigned to one navigation command.
- **Linear speed.** Set the linear camera motion speed in meters per second in this field. The camera moves in virtual space with this speed while you are holding down a key, assigned to the camera linear motion command.
- **Angle speed.** Set the camera rotation speed in degrees per second in this field. The camera turns with this speed while you are holding down a key, assigned to the camera rotation command.
- **Acceleration.** Set the value of linear or angular camera motion acceleration coefficient. The motion will be accelerated by this value while you hold Shift key together with the navigation command key.
- **Assign** Click this button to assign the new keyboard key to the selected navigation command.
- **Remove** Click this button to remove currently assigned keyboard key from a list of keys associated with the selected navigation command.
- **Reset All** Click this button to revert to the default **ISB** keyboard commands assignments.

To make all keyboard commands assignments permanent and close the dialog box:

- Click the OK button

To cancel all keyboard assignments you have made and close the dialog box:

- Click the Cancel button.

## Customizing Toolbars

### Display or hide toolbar

To display or hide a toolbar:

- 1 Choose Toolbars from the View menu. The Toolbars dialog box, listing the default toolbars appears.
- 2 Mark the toolbar checkbox to display the toolbar, or clear the checkbox to hide it.

**Note:**

To quickly display or hide a toolbar right-click any toolbar. After the pop-up menu appears click the toolbar name to affect its display. A check mark indicates the toolbar is active and displayed. Clicking it again removes the check mark and hides the toolbar.

### Disable or enable custom toolbar

You may enable or disable a custom toolbar in the Plan, Texture Mapper or Painter window.

To enable/disable a toolbar:

- 1 Choose Toolbars on the View menu. The dialog box with toolbar names appears.
- 2 Click the name of the custom toolbar to be disabled in the current window.
- 3 Click Enable/Disable to enable/disable the custom toolbar. The name of the button is switched between Enable or Disable each time it is clicked. The name of the toolbar is also enabled or disabled from the list of available toolbars in the context menu, which opens if you right-click any toolbar on the *ISB* screen.

**Note:**

You cannot disable *ISB*'s built-in toolbars.

### Move a toolbar

- 1 Point between buttons on a toolbar, or point to the toolbar title bar if it is a floating toolbar.
- 2 Drag the toolbar to a new location. If you drag it to the edge of an *ISB* window, the toolbar docks to this edge automatically.

### Resize a toolbar

To resize a floating toolbar, drag any of its sides.

**Note:**

- You cannot resize a docked toolbar.
- Floating toolbar. A toolbar that is not docked to the edge of any *ISB* window. Such a toolbar has a title on the top of its window.
- Docked toolbar. A toolbar that is attached, or anchored, to an edge of *ISB* window. Its window has no title. You may dock the toolbar below the menu or to the left, right, top, or bottom edge of the

window. When you drag a toolbar to the edge of the window, the toolbar outline snaps to the edge. When you drop the toolbar after its outline snaps, it docks to the edge of the window.

## Restore a built-in toolbar

- 1 Choose Toolbars on the View menu. The dialog box with toolbar names appears.
- 2 Click the name of the built-in toolbar to be restored.
- 4 Click Reset. The built-in, default state of the toolbar is restored.

## Create a custom toolbar

To create a custom toolbar:

- 1 Choose Toolbars from the View menu. The dialog box with toolbar names appears.
- 2 Click New. The Customize Toolbars dialog box appears.
- 3 In the field "Toolbar name enter the name of the new toolbar.
- 4 Mark the "Available in global scope checkbox to make the toolbar available while working in the Plan, Texture Mapper, and Painter windows. Clear the checkbox to make the toolbar available during work in the current view only.
- 5 Click OK. An empty toolbar appears on the screen. The Customize Toolbars dialog box appears.
- 6 In the Categories box, click the category that contains the desired button.
- 7 Drag the desired button onto the new toolbar.
- 8 Repeat the last two steps for all required buttons.
- 9 Click Close. The Customize Toolbars dialog box disappears.

## Delete a custom toolbar

To delete a custom toolbar:

- 1 Choose Toolbars from the View menu. The Customize Toolbars dialog box appears.
- 2 Click the name of the toolbar to be deleted.
- 3 Click Remove. The toolbar is removed.

**Note:**

- You cannot remove the *ISB* built-in toolbars.

## Rename a custom toolbar

To rename a custom toolbar:

- 1 Choose Toolbars on the View menu. The Customize Toolbars dialog box appears.
- 2 Click the name of the toolbar.
- 3 Enter the new name in the Toolbar name field.
- 4 Click Close. The toolbar is renamed.

**Note:**

You cannot rename the *ISB* built-in toolbars.



## Add or delete a toolbar button

To add a toolbar button:

- 1 Choose Customize on the Tools menu. The Customize Toolbars dialog box appears.
- 2 In the Categories box, click the category that contains the desired button. All buttons of this category appear in the Buttons box.
- 3 Drag the desired button from the Buttons box to the new toolbar. The button appears on the toolbar.
- 4 Click Close. The button is added.

To delete a toolbar button:

- 1 Hold down the Alt key and then drag the button to be deleted from the toolbar onto any *ISB* window.
- 2 Release the Alt key. The button is deleted.

**Note:**

If the Customize Toolbars dialog box is open you may drag buttons without pressing the Alt key.

## Change the spacing between toolbar button

To increase a space between two toolbar buttons:

- 1 Hold down the Alt key and drag the right button a little bit to the right.
- 2 Release the Alt key. The distance between the tools is increased.
- 3 Repeat the last operation for all other buttons, with the exception of the upper left.

To decrease a space between two toolbar buttons:

- 1 Hold down the Alt key and drag the right button a little bit to the left.
- 2 Release the Alt key. The space is decreased.
- 3 Repeat the last operation for all other buttons, with the exception of the upper left.

## Move or copy a toolbar button

To move a toolbar button to another toolbar:

- 1 Hold down the Alt key and then drag the button to the required toolbar.
- 2 Release the Alt key. The button is moved.

To copy a toolbar button:

- 1 Hold down the Alt and Ctrl keys and then drag the button to the required toolbar.
- 2 Release the Alt and Ctrl keys. The button is copied.

## Troubleshooting

- A texture won't spread to another face.  
The face belongs to another object. You can only spread textures over faces of the same object.
- Only the top view of a plan is printed as a result of the Print command on the File menu.  
You can only print views shown on the screen. To print a front, view make sure it is visible.
- The objects in the Object gallery are not textured.  
This means the textures are loading. In this case the rotating globe is shown on the bottom of the *ISB* window. The objects will display any textures after they are loaded.
- The picture is too small when placed into the Perspective View window.  
If you want the pictures to be larger when you place them into the Perspective View window click Options on the Tools menu, then click the Camera tab. Define smaller values in the Horizontal and Vertical edit boxes. These boxes specify how many pixels of picture imaging correspond to one meter of virtual scene.
- CosmoPlayer doesn't process an URL link when you click the object.  
If an object has an URL link as well as a sound file attached to it, CosmoPlayer will only play the sound after the object is clicked.
- A scene isn't textured when viewing with CosmoPlayer.  
If you save the scene using the Save or Save As command on the File menu, the scene references textures, pictures, movies, and objects locally. For correct URL links which allow you to publish a scene and view it using any VRML viewer use the Publish or Post to Web command from the File menu.
- When a picture is placed into another location it changes its size.  
Each time a picture is placed onto an object's face *ISB* calculates an appropriate size, one corresponding to the size of the face. Place a picture in the correct position before specifying its size.
- The Cut, Copy or Extract commands are not working in certain cases. The Extract, Cut and Copy operations are not available to the Room and Walls shapes and to convex custom shapes.

## Reference

This reference contains brief information on *ISB's* menus and toolbars. Here, you can find some useful features that were not explained above.

### Main Menu

*ISB* has a standard Windows menu with pull-down menus for several categories of commands.

#### File

Contains commands for managing files, choosing scenes in the Scene gallery, getting scene info, printing the plan and exiting *ISB*.

New	Creates a new empty scene with default camera position, grid spacing, etc.
Open	Opens a scene from the specified file.
Choose	Opens a scene from the Scene gallery (Double-click the selected scene).
Save	Saves the current scene into the same file. The scene can be saved in VRML 2.0 or VRML 2.0 compressed (gzip) format.
Save as	Saves the current scene under a specified file name. The scene can be saved in VRML 2.0 or VRML 2.0 compressed (gzip) format.
Info	Displays information about the scene such as number of faces, pictures, movies, etc.
Publish	Creates a directory for your scene and copies the .WRL file and all scene resources like textures, pictures etc. into the directory. This creates a distribution package of your 3D scene which you can publish on the Web. The scene can be saved in VRML 2.0 or VRML 2.0 compressed (gzip) format.
Post To Web	Uploads your 3D space to a WWW server.
Set Background	Opens the Background dialog which allows you to set the scene background images and landscape.
Attach MIDI	Attaches a MIDI file to the current scene. This file plays while the scene is loading.
Detach MIDI	Detaches the MIDI file from the current scene.
Print Setup	Define printer parameters.
Print	Prints scene plan.
Exit	Exits <i>ISB</i> .

#### Edit

Contains commands for scene editing. *ISB* has two different clipboards, used for cutting/copying/pasting operations: standard Windows Clipboard for image data and special *ISB* clipboard for scene geometry data.

Undo	Cancels the latest editing operation.
Redo	Redoes the last operation that was undone.
Cut	Cuts the selected part of scene, object or image or the entire selected object and places it on the clipboard. For the shape, included into the scene or object this command is equivalent to the Extract shape command, except that it places the removed part of the scene or object on the clipboard.

Copy	Copies the selected part of the scene, object or image, or the entire selected object and places it on the clipboard.
Paste	In the Scene Assembling or Object Editing mode inserts the object currently stored in the clipboard to the scene. In the Painter mode inserts the Windows Clipboard image data into the edited picture or texture.
Delete	Deletes the selected part of the scene, object or image, or the entire selected object, without placing it on the clipboard. When deleting a shape, included into the scene or object, this command is equivalent to the Extract shape command.

### View

Contains commands for displaying/hiding various ISB screen elements.

Toolbars	Displays or hides selected toolbars, creates new toolbars and resets toolbars to their default settings.
Switch Bar	Displays/hides the Switch bar located at the bottom of the Plan windows, which allows you to switch between the ISB modes by clicking the corresponding tabs.
Status Bar	Displays/hides the status bar located in the bottom line of the screen.
Scene Plan, Object Plan, Texture Mapper, Painter	Switches between these modes of ISB operation.
Perspective View	Displays/hides the Perspective View window.
Clipboard	Displays or hides the Clipboard Content window. Clipboard Content window is located by default at the bottom right corner of the ISB screen in the Basic layout and shows the items placed onto the ISB clipboard as a result of Cut or Copy operations.
Scene tree	Displays/hides the Scene tree window.
Scenes	Displays/hides the Scene gallery.
Textures	Displays/hides the Texture gallery.
Pictures	Displays/hides the Picture gallery.
Movies	Displays/hides the Movie gallery.
Shapes	Displays/hides the Shape gallery.
Objects	Displays/hides the Object gallery.

### Camera

Contains commands for controlling ISB's camera.

Align Horizontal	Makes camera's horizontal axis parallel to the scene horizon.
Align Vertical	Makes camera's longitudinal axis parallel to the scene horizon.
Go To Object	Move camera closer to the current object.
Set Light Direction	Sets a light source direction of the scene towards the active camera view.
Duplicate	Create a new camera at the same location and with the same orientation as the current camera.
Rename	Specify a new name for the current camera.
Delete	Deletes the current camera. Available only if there are two or more cameras.

Use collider	Enables or disables collision detection while navigating the camera in the Perspective View window. With Collision detection ON the camera can not move through the faces.
Gravity	Enables or disables the gravitation effect on the current camera during the navigation in the Perspective View window. With Gravitation ON the camera always falls down on the face under it. If there is no face under the camera, the gravity is turned off automatically.

### Object

Contains commands to manipulate scene objects.

New	Empty object - creates a new object as a sub-object of current object and switches ISB to the Object Editing mode. Box - creates new VRML primitive object Box Cone - creates new VRML primitive object Cone Cylinder - creates new VRML primitive object Cylinder Sphere - creates new VRML primitive object Sphere Plain Text - creates new VRML primitive object Text
3Dtext	Creates a text string, composed from 3D symbols as a new object. You can enter text and format it with any of the True Type fonts installed in your Windows system.
Import	Imports an object from a 3DS file into the Object gallery.
Save	Saves the current object. The object can be saved in VRML 2.0 or VRML 2.0 compressed (gzip) format.
Manipulate	Enables the Object Manipulator in the Perspective View window.
Mirror	Mirrors current object from the vertical arm of its Object Manipulator
Add Shape	Adds the current shape to the scene.
Extract Shape	Extracts the current shape from the current object.
Attach Sound	Attaches a sound file (WAV) to the selected object.
Play Sound	Plays the sound file (WAV) attached to the selected object.
Detach Sound	Detaches the sound file from the selected object.
Link URL	Attaches an URL to the selected object.
Remove URL	Removes the URL from the selected object.

### Layout

Contains commands to control screen layout.

Basic	This is default ISB layout. This layout allows you to assemble scene from ready elements and decorate your virtual world.
List	Opens a list of custom layouts. You may add a new layout to the list and use it in your work.

### Tools

Contains commands for setting ISB parameters and creating new shapes for the Shape gallery.

Customize	Customizes the toolbars.
Options	Sets ISB parameters. The parameters control screen appearance, editing, rendering, navigation, resources and other options.

Record Shape	Starts recording of merging and carving operations resulting in a new shape. After the recording is stopped you can save recorded shape (command sequence - macro command) into the Shape gallery.
Stop Recording	Stops recording and opens a dialog box to save the new shape.

### Help

Contains commands to get help and additional information on ISB

Help Topics	Displays the ISB Help window.
Tip of the Day	Displays an ISB tip.
Product News	Downloads the ISB news page from the ParallelGraphics Web site.
ParallelGraphics Home Page	Downloads the ParallelGraphics home page.
About ISB	Displays the ISB version number and copyright information.

### Text

Contains commands for editing the Plain Text object in the Object Editing mode.

Format	Opens the Format dialog box for the Plain text object.
Save Text	Saves Plain Text object in the object gallery.
Attach Sound	Attaches a sound file (WAV) to the selected object.
Play Sound	Plays the sound file (WAV) attached to the selected object.
Detach Sound	Detaches the sound file from the selected object.
Link URL	Attaches an URL to the selected object.
Remove URL	Removes the URL from the selected object.







## Toolbars





Toolbars include control buttons. Some are shortcuts to menu commands while others appear only in toolbars. The toolbars of the Basic layout are described below.

### Standard

Contains buttons for managing files as well as selecting and editing scene.















-  New - Shortcut to the File/New command.
-  Open - Shortcut to the File/Open command.
-  Choose - Shortcut to the File/Choose command.
-  Save - Shortcut to the File/Save command.
-  Undo - Shortcut to the Edit/Undo command.
-  Redo - Shortcut to the Edit/Redo command.

-  Cut - Shortcut to the Edit/Cut command.
-  Copy - Shortcut to the Edit/Copy command.
-  Paste - Shortcut to the Edit/Paste command.
-  Print - Shortcut to the File/Print command.
-  Help - Provide context help.

## Plan

Contains buttons for mode selection, zooming, displaying the ruler, guides and grid, as well as fitting plan to the Plan window and browsing through the Scene tree.









-  Build Mode - Turns the Build mode on/off. In this mode, you can perform Boolean operations with shapes from the Shape gallery. Boolean operations consist of adding shapes to the scene or extracting shapes from the scene to create complex 3D objects.
-  Polygon Mode - Turns the Polygon mode on/off. In this mode, you can specify the underlying polygon and then create a solid polyhedral, walls, room or pyramid using one of the Edit toolbar buttons: , , , or .
-  Zoom Mode - Turns the Zoom mode on/off. In this mode, you can reduce or increase view magnification as well as select an area in the Top or Front View windows for zooming. To select an area, draw a rectangle with the mouse. The area is immediately magnified after you release the left mouse button.
-  Move Plan Mode - Turns the Move plan mode on/off. In this mode, you move both views in the Plan window in the drag direction.
-  Zoom Out - Reduces magnification.
-  Zoom In - Increases magnification.
-  Ruler - Displays/hides the Ruler window.
-  Fit to Scene - Adjusts view size to fit both views to their windows.
-  Fit to Object - Adjusts the current object view size to fit both views to their windows.

## Edit

Contains the buttons for editing the scene and creating new shapes.



-  New Object - Shortcut to the Object/New command.
-  Add - Shortcut to the Object/Add Shape command.
-  Extract - Shortcut to the Object/Extract Shape command.
-  Solid - Creates a solid polyhedral after the vertexes of the underlying polygon are defined. Accessible in the Polygon and Spline modes.
-  Walls - Creates walls after the vertexes of the underlying polygon are specified. Accessible in the Polygon and Spline modes.
-  Room - Creates a room after the vertexes of the underlying polygon are specified. Accessible in the Polygon and Spline modes.



Pyramid - Creates a pyramid after the vertices of the underlying polygon are specified. Accessible in the Polygon and Spline modes.

## Camera

Contains the buttons for camera control.



Duplicate - Shortcut to the Camera/Duplicate command.



Align Horizontal - Shortcut to the Camera/Align Horizontal command.



Align Vertical - Shortcut to the Camera/Align Vertical command.



Go To Object - Shortcut to the Camera/Go To Object command.



Collider - Shortcut to the Camera/Use Collider command.

## Brush



Spread - Spreads a material from one face to an adjacent face. To spread a material:

1. Click the Spread button.
2. In the Perspective View window, move the mouse pointer to the face with a required material.
3. Hold the left mouse button.
4. Drag the material to any adjacent face.



Fill - fills a face or an object with the material from the Material bar.

When this button is pressed:

- If you single click a face in the Perspective View window, Fill copies the material from the Material bar to this face.
- If you Double-click a face in the Perspective View window, Fill fills all connected faces of the object with the material from the Material Bar.



Pick - copies the material properties of a face into the material bar. To copy the material properties of the face in the Material bar:

Click Pick button and then click the face in the Perspective View window.

## Texture

Contains buttons for texture editing with mapping operations.



Shrink - Reduces the texture image tiling period on the face.



Expand - Increases the texture image tiling period on the face.



Orthogonalize - Makes the texture axes perpendicular to each other.



Central symmetry - Rotates the texture image 180 degrees around a pin.



Rotate - Rotates the texture 90 degrees counter-clockwise around a pin.



Mirror - Mirrors the texture relative to the line between the two pins.





Align Horizontal - Rotates the texture image to make its horizontal axis parallel to the line between the two pins.



Align Vertical - Rotates the texture image to make its vertical axis parallel to the line between the two pins.



Default - Restores the default texture tiling and mapping parameters, specified in the Tools/Options/Texture Mapper dialog.

### Painter

Contains commands for creating and saving pictures and textures as well as defining names and categories.



New Picture - Creates a new picture.



New Texture - Creates a new texture.



Save - Saves current picture or texture into the gallery.

### Paint

Contains commands to select a drawing instrument, define its shape and select painting operations.



Pencil - Selects a pen for drawing. The pen width can be defined using the Width and Shape pane on the bottom of the Paint toolbar.



Stylus - Selects a stylus for drawing. The stylus width can be defined using the Width and Shape pane on the bottom of the Paint toolbar.



Brush - Selects a brush for drawing. The brush width can be defined using the Width and Shape pane on the bottom of the Paint toolbar.



Fill - Fills an area of connected points with a color.



Line - Draws a straight line. The line width can be defined using the Width and Shape pane on the bottom of the Paint toolbar.



Rectangle - Draws a rectangle. The line width can be defined using the Width and Shape pane on the bottom of the Paint toolbar.



Select Color - Pick up a color from any point on the picture or texture.





Select - Selects a rectangular part of a picture or a texture.



Magnify - Magnifies a picture or a texture. The value of magnification can be defined using the Width and Shape pane on the bottom of the Paint toolbar.

### Set tool properties box (Paint toolbar)

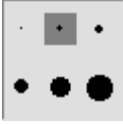

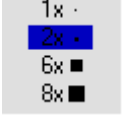
You can set the properties of current painting/editing tool by clicking the items in this box. The following options are available:

-  Drawing shape - for Pencil, Stylus and Brush.
-  Line width - for Line and Rectangle.
-  Selection mode - for Select tool.
-  Zoom value - for the Magnify button.

### Attributes

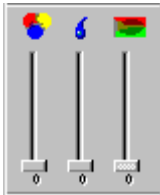
Contains commands to define a drawing attribute.





-  Transparency - Sets the desired transparency of the color.
-  Water - Sets the desired saturation of the color.
-  Tolerance - Sets the difference of the point colors when filling an area.

### Formatting

Contains commands to edit the Plain Text object in Object Editing mode.



 Alignment. Select the alignment click the corresponding button on the Formatting toolbar.

 Text. Click this button to open the Format dialog box. To edit the text when the Format dialog box is closed click the arrow to the right from the Text button and edit the text in a small textbox which drops down. The text may contain several lines. Each line is located below the previous line for the horizontal text orientation or to the right from the previous line for vertical text orientation.

 Font style. To select font style click Bold or Italic buttons on the Formatting toolbar.



 Font. Select a font from the list of available fonts.

 Orientation. Select the text lines orientation. Note, that the characters in the lines of the Plain Text object always have vertical orientation.

## Material

You can modify the material properties of faces using this toolbox.



- Button bar. Contains three buttons:
  -  Go to Face button. Moves the camera in the position, suitable for viewing the face, which material you are editing.
  -  Clear button. Removes the texture from the current material. The face color becomes visible after this button was pressed.
  -  Stop button. Stops the texture animation.
- Material Preview window. A sample sphere with current material properties is shown in this section of the Material bar.
- Color control sliders section. You can set the RGB value of the material color in this section. The color is placed under the texture, so it becomes visible only if the face is not textured.
- Color Circle. To define a custom color, click anywhere in this circle, and then use the Luminosity slider below to adjust the color's attributes. If you define a color using the Red/Green/Blue scales, you can look at this circle to make sure you defined the color as you intended.
- Luminosity control slider (at the left). You can set the possible amounts of white and black in the color by dragging it up or down.
- Transparency control slider. Drag this slider to set the transparency value of the current material.
- Color palette section. Shows the basic colors available. To define a custom color, Double-click the color cell to open Color dialog box.
- This is the texture animation control of the Material bar. It is used to create moving textures.

To animate the current texture:

1. Drag the central green circle in the direction of the texture motion.
2. The red arm of the animation control is displayed. A longer arm means faster motion. The direction of the texture motion is defined with arm direction.

To stop animation:

- Click the Stop button on the toolbar at the top of the Material bar.

# Index

## 3

3D scene .....	6
concept .....	6

## A

Add .....	43, 76
adding and extracting shapes .....	43
toolbar button .....	76
Align camera .....	14
Animate textures .....	61
Apply .....	18, 31, 32, 33
default texture .....	31
face material .....	31
shapes to scene .....	18
texture .....	32
Attach sound .....	56

## B

Background .....	25, 26, 29
editing colors .....	29
overview .....	25
Basic layout .....	4
Box .....	51
Building scene .....	6

## C

Camera .....	11, 12, 13, 14, 15
align .....	14
control .....	11
delete .....	15
duplicate .....	14
navigate camera in Ruler window .....	13
navigate in Perspective View window .....	12
navigate in Plan window .....	12
rename .....	14
select .....	14
Change .....	20, 35, 42, 43, 61, 76
object heights using Ruler .....	43
object size and position using Object manipulator .....	42
picture/movie location .....	35
shape height .....	20
spacing between toolbar buttons .....	76
texture transparency .....	61
Clipboard Content window .....	37, 38
Color .....	33, 34, 64, 65
fill an area .....	63
pick up a point color .....	65
setting .....	33
setting specific color as transparent .....	64
spread .....	33
Concept of ISB .....	6
Cone .....	53
Construct scene geometry .....	15
Control .....	11, 18, 19, 66
camera .....	11
gallery resources .....	66
shape heights .....	18
Copy .....	34, 40, 41, 43, 44, 62
modified textures to faces .....	62

object into another hierarchy level.....	41
object into another scene place.....	40
objects.....	43
picture/movie.....	34, 35
Create.....	10, 20, 39, 63, 75
custom shapes.....	20
custom toolbar.....	75
new picture or texture.....	63
new scene.....	10
object.....	39
Customizing.....	5
layout.....	5
Cut.....	43, 44
objects.....	43
Cylinder.....	52, 53
<b>D</b>	
Delete.....	15, 35, 40, 75
camera.....	15
custom toolbar.....	75
object.....	40
picture/movie.....	35
Detach sound.....	57
Draw.....	63
free-form line.....	63
straight line.....	63
Duplicate camera.....	14
<b>E</b>	
Edit.....	8, 9, 41, 65
object.....	41
object in the Object Editing mode.....	8
picture or texture.....	65
Extracting Shapes.....	43
<b>F</b>	
Face.....	33, 34
put movie/picture.....	34
setting color.....	33
Fill an area with a color.....	63
Fit22, 41.....	
window to object.....	41
window to scene.....	22
Frequently asked questions.....	3
Frozen part of scene.....	6
<b>G</b>	
Gallery.....	9, 66
controlling resources.....	66
files.....	9
using galleries of ready items.....	9
Get.....	2, 40
assistance during your work.....	2
object Info.....	40
Grid.....	21
<b>H</b>	
Hardware and system requirements.....	2
Help.....	2
How does ISB store the files of galleries.....	9
<b>I</b>	
Import object.....	38
Include.....	15, 16

ready shape into scene .....	15
shape created on the fly .....	16
Installation .....	2
ISB .....	1, 2, 3, 25
features .....	1
frequently asked questions.....	3
hardware and system requirements .....	2
installation .....	2
sizing and scaling limits.....	25
technical support .....	3
uninstalling .....	3

**K**

Keeping the virtual world clear .....	8
---------------------------------------	---

**L**

Layout .....	4, 5
customizing .....	5
Line .....	63
Link URL .....	57

**M**

Manipulator .....	24, 45
object in the Perspective View window.....	45
shape in the Perspective View window.....	24
Mapping .....	59, 60
one pin .....	59
two pins .....	60
Material .....	30, 32, 33, 34
default settings .....	30
overview of material properties.....	30
setting color .....	33
setting texture.....	32
spread .....	33, 34
Menus .....	5
Modes of scene construction.....	8
Move .....	40, 41, 59, 74, 76
move or copy toolbar button.....	76
object into another hierarchy level.....	41
object into another scene place.....	40
texture .....	59
toolbar .....	74
Movie/picture .....	34, 35
change location .....	35
copy.....	34, 35
deleting.....	35
put to face.....	34
resizing .....	35
specify play order .....	34

**N**

Navigate camera .....	12, 13
in Perspective View window .....	12
in Plan window .....	12
in Ruler window .....	13
New .....	10, 63
picture or texture .....	63
scene.....	10

**O**

Object.....	7, 8, 9, 36, 37, 38, 39, 40, 41, 42, 43, 44, 45, 46, 47, 48, 49, 50, 51, 52, 53, 54
change heights using Ruler.....	43
change size and position/orientation using Object manipulator.....	42
creating .....	39

cut/copy and paste .....	43
deleting.....	40
edit .....	41
editing in the Object Editing mode.....	8
fit to window.....	41
get Info .....	40
importing.....	38
manipulating in the Perspective View window .....	44
manipulator in the Perspective View window.....	45
move and copy into another hierarchy level .....	41
move and copy into another scene place .....	40
moving and snapping to face.....	47
placing into the scene.....	36
renaming .....	40
rotating with the manipulators in the Perspective View window.....	45
saving current.....	39
scaling in the Perspective View window .....	46
select.....	38
structured scene example .....	7
using.....	36
VRML primitive Box.....	51
VRML primitive Cone .....	53
VRML primitive Cylinder.....	52
VRML primitive Sphere .....	54
One pin mapping .....	59
On-line picture or texture editing .....	65
Open .....	10
existing scene.....	10

## P

Painter.....	62, 63, 64
placing existing texture .....	63
select area.....	64
show Painter window.....	62
ParallelGraphics Web Site .....	3
Perspective View.....	23, 24, 44
manipulations with objects .....	44
placing shapes .....	23
re-sizing shapes .....	24
Phases of building virtual space.....	10
Pick up a point color .....	65
Picture .....	63, 65, 66
creating new.....	63
editing.....	65
resizing.....	65
saving.....	65, 66
Pivot point .....	59
Place existing texture to Painter window .....	63
Place texture to Texture Mapper window .....	59
Play sound .....	57
Print.....	23
plan .....	23
Publishing scene .....	58
Put picture/movie to face.....	34

## Q

Questions .....	3
-----------------	---

## R

Remove.....	58, 61
texture .....	61
URL.....	58
Rename.....	14, 40, 75
camera .....	14, 15
custom toolbar.....	75

object.....	40
Resize .....	17, 18, 35, 65, 74
picture or texture .....	65
picture/movie .....	35
shape .....	17, 18
toolbar .....	74
Resources .....	66, 67, 68, 69, 70, 71
changing the reference in the scene .....	69
modifying used in the scene resources .....	67
renaming .....	69
viewing the use.....	68
Restore initial texture.....	61
Rotate plan.....	21
Ruler window.....	19
control shape height.....	18
Ruler Window.....	13, 14
navigate Camera .....	13
<b>S</b>	
Save .....	11, 39, 65, 66
current object.....	39
picture or texture .....	65
scene.....	11
Scale .....	46, 47
object.....	46, 47
Scene .....	6, 7, 8, 10, 11, 15, 18, 25, 26, 36, 58, 67, 68, 69, 70
apply shapes to scene.....	18
building tips .....	8
changing the reference to the resources .....	69
choose from gallery .....	10
concept.....	6
construct geometry .....	15
create new.....	10
frozen part of scene example .....	6
modifying the resources .....	67
open existing .....	10
preparing for publishing.....	58
renaming the resources.....	68
save.....	11
setting background.....	25
structured scene.....	7
tree .....	36
two modes of construction.....	8
upload to WWW .....	58
Screen layout .....	4
Scroll .....	20, 22
plan .....	22
Ruler.....	20
Select .....	14, 38, 64
area .....	64
camera .....	14
object.....	38
Set.....	17, 19, 33, 34
default shape height .....	19
face color.....	33
picture/movie to face .....	34
shape position	
size	
and orientation.....	17
Setting the scene background and landscape scheme .....	26
Setup.....	2
Shape.....	15, 16, 17, 18, 19, 20, 21, 23, 24, 43
adding and extracting .....	43
apply to scene .....	18
change height.....	20
controlling height .....	18



create custom shapes .....	20
include ready shape into scene .....	15
include shape created on the fly .....	16
placing in the Perspective View window .....	23
re-sizing in the Perspective View window .....	24
set default height .....	19
set position	
size	
and orientation .....	17
Show .....	58, 62
Painter window .....	62
Texture Mapper window .....	58
Snap .....	47
object to face .....	47
Sound .....	56, 57
attach .....	56
detach .....	57
play .....	57
Specify movie play order .....	34
Sphere .....	54
Split Plan window .....	21
Spread texture or color .....	33
Structured scene .....	7
Support .....	3

## T

Take component .....	36
Technical support .....	3
Text .....	54, 55
Plain Text object .....	54, 55
Texture .....	31, 32, 33, 34, 58, 59, 61, 62, 63, 65, 66
animating .....	61
applying .....	32
applying default .....	31
changing transparency .....	61
copying modified textures to faces .....	62
creating cew .....	63
display Texture Mapper window .....	58
editing .....	65
moving .....	59
placing to the Texture Mapper window .....	59
removing .....	61
Resizing .....	65
restore Initial .....	61
saving .....	65
spread .....	33
Tips for scene structure .....	8
Toolbars .....	74, 75, 76
add or delete a toolbar button .....	76
change the spacing between toolbar buttons .....	76
create a custom toolbar .....	75
delete a custom toolbar .....	75
disable or enable toolbar .....	74
display or hide toolbar .....	74
move a toolbar .....	74
move or copy a toolbar button .....	76
rename a custom toolbar .....	75
resize a toolbar .....	74
Restore a Built-in Toolbar .....	75
Transparent color .....	64
Troubleshooting .....	77
Turn grid on/off .....	21
Two pins mapping .....	60

## U

Uninstalling .....	3
--------------------	---

Upload a scene to WWW .....	58
URL .....	57, 58
link .....	57
remove .....	58
Use .....	31, 36, 55
3D fonts .....	55
colors and textures .....	31
face materials .....	30
objects .....	36

## V

Viewing .....	68
where the resource is used .....	68
VRML primitives .....	51, 52, 53, 54
Box .....	51, 52
Cone .....	53
Cylinder .....	52
overview .....	51
Sphere .....	54
VRML Text node .....	54

## W

Web Site .....	3
What is ISB .....	1
Working with menus .....	5
Working with the resources .....	67

## Z

Zoom .....	22, 65
picture or texture .....	65
zoom of plan .....	22